



Ruijie RG-CS88-08 Series Switches

Hardware Installation and Reference Guide

Document Version: V1.6
Date: 2024-09-12
Copyright © 2024 Ruijie Networks

Copyright

Copyright © 2024 Ruijie Networks

All rights are reserved in this document and this statement.

Without the prior written consent of Ruijie Networks, no organization or individual is permitted to reproduce, extract, back up, modify, or distribute the content of this document in any manner or form. It is also prohibited to translate the document into other languages or use any or all parts of it for commercial purposes.

 and  trademarks are owned by Ruijie Networks.

All other trademarks or registered trademarks mentioned in this document are owned by their respective owners.

Disclaimer

The products, services, or features that you purchase are subject to commercial contracts and terms. It is possible that some or all of the products, services, or features described in this document may not be available for purchase or use. Unless agreed upon otherwise in the contract, Ruijie Networks does not provide any explicit or implicit statements or warranties regarding the content of this document.

The names, links, descriptions, screenshots, and any other information regarding third-party software mentioned in this document are provided for your reference only. Ruijie Networks does not explicitly or implicitly endorse or recommend the use of any third-party software and does not make any assurances or guarantees concerning the applicability, security, or legality of such software. You should choose and use third-party software based on your business requirements and obtain proper authorization. Ruijie Networks assumes no liability for any risks or damages arising from your use of third-party software.

The content of this document is subject to constant change due to product version upgrades or other reasons. Thus, Ruijie Networks reserves the right to modify the content of the document without prior notice or prompt.

This manual serves solely as a user guide. While Ruijie Networks endeavors to ensure the accuracy and reliability of the content when compiling this manual, it does not guarantee that the content of the manual is free of errors or omissions. All information contained in this manual does not constitute any explicit or implicit warranties.

Preface

Intended Audience

This document is intended for:

- Network engineers
- Technical support and servicing engineers
- Network administrators

Technical Support

- Ruijie Networks website: <https://www.ruijienetworks.com/>
- Online support center: <https://ruijienetworks.com/support>
- Case portal: <https://caseportal.ruijienetworks.com>
- Community: <https://community.ruijienetworks.com>
- Email support: service_rj@ruijienetworks.com
- Live chat: <https://www.ruijienetworks.com/rita>
- Documentation feedback: doc@ruijie.com.cn

Conventions

1. Signs

The signs used in this document are described as follows:

Danger

An alert that contains important safety instructions. Before you work on any equipment, be aware of the hazards involved and be familiar with standard practices in case of accidents.

Warning

An alert that calls attention to important rules and information that if not understood or followed can result in data loss or equipment damage.

Caution

An alert that calls attention to essential information that if not understood or followed can result in function failure or performance degradation.

Note

An alert that contains additional or supplementary information that if not understood or followed will not lead to serious consequences.

Specification

An alert that contains a description of product or version support.

2. Note

The manual provides configuration information, including models, port types, and command line interfaces, for reference purposes only. In the event of any discrepancy or inconsistency between the manual and the actual version, the actual version shall take precedence.

Contents

Preface	I
1 Product Overview	1
1.1 RG-CS88-08	1
1.1.1 Specifications	1
1.1.2 Product Appearance	3
1.1.3 Package Contents.....	7
1.2 Supervisor Modules	8
1.2.1 CM88-CM.....	8
1.2.2 Package Contents.....	11
1.3 Switch Fabric Modules.....	11
1.4 Line Cards.....	11
1.4.1 CM88-48GT-H.....	11
1.4.2 CM88-48SFP-H	12
1.4.3 CM88-48XS-H.....	14
1.4.4 CM88-8CQ-H	16
1.4.5 Package Contents.....	18
1.5 Power Modules	18
1.5.1 RG-PA600I-F	18
1.5.2 RG-PA1600I-F.....	19
1.6 Fan Modules	21
1.6.1 M08-FAN	21
1.6.2 Package Contents.....	22
1.7 Pluggable Modules	22

- 2 Preparation before Installation 24
 - 2.1 Safety Suggestions 24
 - 2.1.1 General Suggestions 24
 - 2.1.2 Safety Precautions for Removal 24
 - 2.1.3 Electrical Safety 24
 - 2.1.4 Static Discharge Damage Prevention..... 25
 - 2.1.5 Laser Safety 26
 - 2.2 Installation Site Requirements 26
 - 2.2.1 Load Bearing Requirements 26
 - 2.2.2 Space Requirements 27
 - 2.2.3 Ventilation Requirements 27
 - 2.2.4 Temperature Requirements 27
 - 2.2.5 Humidity Requirements 28
 - 2.2.6 Cleanness Requirements 28
 - 2.2.7 Power Requirements 29
 - 2.2.8 System Grounding Requirements 30
 - 2.2.9 EMI Consideration 31
 - 2.3 Cabinet Mounting..... 31
 - 2.4 Installation Tools 32
 - 2.5 Precaution for Fiber Connection 33
 - 2.6 Unpacking Requirements 33
- 3 Product Installation..... 34
 - 3.1 Installation Procedure 34
 - 3.2 Installation Verification 35

3.3 Installing the Air Filter (Optional)	35
3.4 Mounting Cable Management Brackets	36
3.5 Mounting the Cabinet.....	37
3.6 Mounting the Switch to a Cabinet.....	39
3.7 Connecting the System Ground	41
3.8 Installing Power Supplies.....	42
3.9 Installing Fans.....	43
3.10 Installing Modules	43
3.11 Installing Swappable Interface Modules (Optional).....	45
3.11.2 Installing SFP+/SFP Modules	46
3.11.3 Installing SFP+ Cables.....	46
3.11.4 Installing 40-Gigabit QSFP+ Modules.....	48
3.11.5 Installing 40-Gigabit QSFP+ Cables	49
3.12 Connecting the Power Cord	51
3.12.1 Connecting the AC Power Cord.....	51
3.13 Installation Verification	51
4 System Debugging	53
4.1 Establishing the Configuration Environment	53
4.2 Power-on Startup	55
5 Monitoring and Maintenance.....	56
5.1 RG-CS88-08 Monitoring	56
5.2 Hardware Maintenance.....	56
6 Troubleshooting.....	58
6.1 General Installation Troubleshooting Flow	58

6.2 Common Troubleshooting Procedures.....	59
7 Replacing Modules.....	62
7.1 Removing, Cleaning and Installing Air Filter	62
7.1.1 Removing, Cleaning and Installing Air Filters for Supervisor and Service Modules ...	62
7.2 Removing Swappable Interface Modules (Optional).....	62
7.2.1 Removing SFP+/SFP Modules.....	62
7.2.2 Removing SFP+ Cables	63
7.2.3 Removing 40-Gigabit QSFP+ Modules	63
7.2.4 Removing 40-Gigabit QSFP+ Cables.....	64
7.3 Replacing Modules	65
7.4 Removing Power Modules.....	66
7.5 Removing Fans.....	67
8 Cables	69
8.1 Connecting the External Port Cables	69
8.2 Bundling the Cables.....	69
9 Appendix.....	70
9.1 Connectors and Media.....	70
9.2 Switch Lightning Protection	71
9.3 Cabling Recommendations.....	74
9.4 Site Selection	77

1 Product Overview

Launched by Ruijie independently, RG-CS88-08 series next generation core switches adopt the Crossbar/FullMesh/Clos architecture and support dual supervisor modules and power supply redundancy.

The RG-CS88-08 switch adopts the module-based design. Compliant with industry standards, the design divides modules and integrates module interfaces to ensure the switch system's functioning and independence of various function modules.

The modules of the RG-CS88-08 switch provide 10/100/1000M auto-sensing Ethernet copper ports, 1000 Mbps/100 Mbps SFP (single-mode/multi-mode) optical fiber interfaces and 10G/40G optical fiber interfaces.

1.1 RG-CS88-08

1.1.1 Specifications

Model	RG-CS88-08
Module slot	2 x supervisor module slots 6 x line card slots 4 x power module slots 2 x fan module slots
Supervisor module	CM88-CM
Switch fabric module	CM88-CM (switch fabric module integrated with supervisor module)
Line card	CM88-48GT-H CM88-48SFP-H CM88-48XS-H CM88-8CQ-H
Power module	RG-PA600I-F RG-PA1600I-F
Fan Module	M08-FAN (pre-installed 2)
Supervisor module redundancy	1+1 redundancy
Power supply	4 x pluggable power modules
Power module redundancy	n+n power redundancy (The type of the power supply should be identical.)
Unit dimensions (W x D x H)	442 mm x 465 mm x 441.7 mm (17.40 in. x 18.31 in. x 17.39 in.)

Rack height	10 RU
Unit weight	35.6 kg (78.48 lbs) (empty chassis with 2 fan modules)
Temperature	Operating temperature: 0°C to 50°C (32°F to 122°F) Storage temperature: -40°C to +70°C (-40°F to +158°F) Note: At an altitude between 3,000 m (9,842.52 ft.) and 5,000 m (16,404.20 ft.), every time the altitude increases by 200 m (656.17 ft.), the maximum temperature decreases by 1°C (1.8°F).
Humidity	Operating humidity: 10% to 90% RH (non-condensing) Storage humidity: 5% to 95% RH (non-condensing)
Altitude	Operating altitude: -500 m to +5,000 m (-1640.42 ft. to +16404.20 ft.) Storage altitude: -500 m to +5,000 m (-1640.42 ft. to +16404.20 ft.)
Mean time between failure (MTBF)	216,000 hours (about 24 years)
Fan	2 x pluggable fan modules
Fan redundancy	1+1 redundancy
Acoustic noise	27°C (80.6°F): 70 dB 45°C (113°F): 77 dB
Module hot swapping	Supported: supervisor modules, line cards
Power module hot swapping	Supported (Switch mode power supplies support hot-swapping power cords)
Fan module hot swapping	Supported
Safety regulation	IEC 62368-1
EMC regulation	EN 300386, EN 55032 Class A, EN 55035, EN IEC 61000-3-2, EN 61000-3-3, EN 61000-4-2, EN 61000-4-3, EN 61000-4-4, EN 61000-4-5, EN 61000-4-6, EN 61000-4-11
RoHS	Supported

 **Note**

The weight only includes that of the empty chassis and fans. The whole device's weight is subject to that of the modules selected.

⚠ Caution

RG-CS88-08 switch is a class A product. In a domestic environment, this product may cause radio interference in which case the user may be required to take adequate measures.

1.1.2 Product Appearance

The hardware system of the RG-CS88-08 switch is composed of the chassis, the power system, modules and the cooling system.

- The power system provides four power supply slots and supports N+N power redundancy.
- The RG-CS88-08 switch provides two supervisor module slots and six service module slots. The supervisor modules support 1+1 redundancy. Users are recommended to configure redundancy for the supervisor modules. Users may choose different service modules as needed.
- The cooling system is composed of the fan trays and air filters. Fan trays are at the back of the chassis. The air filters are on the right side of the chassis.

Figure 1-1 Appearance of the RG-CS88-08 Switch

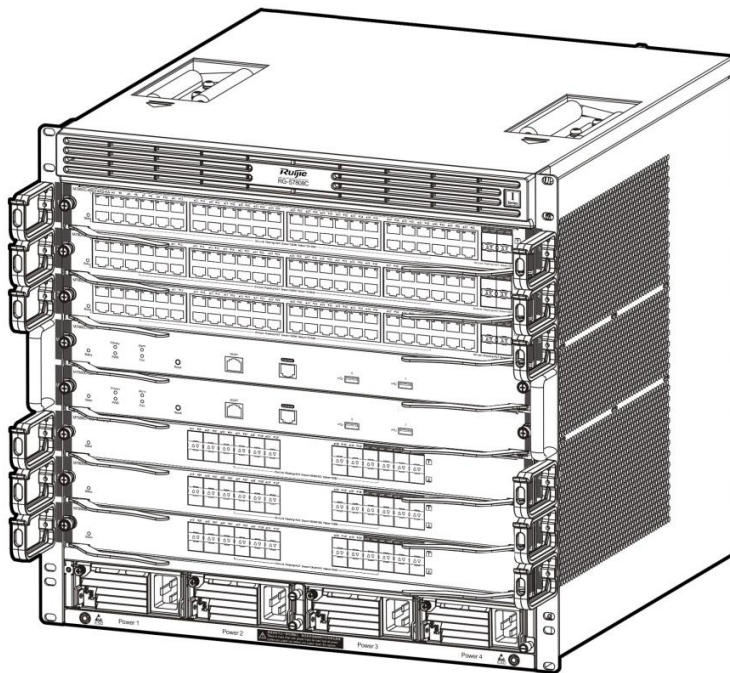

Front Panel

The front panel of the RG-CS88-08 switch is shown in [Figure 1-2](#).

Figure 1-2 Front Panel of the RG-CS88-08 Switch

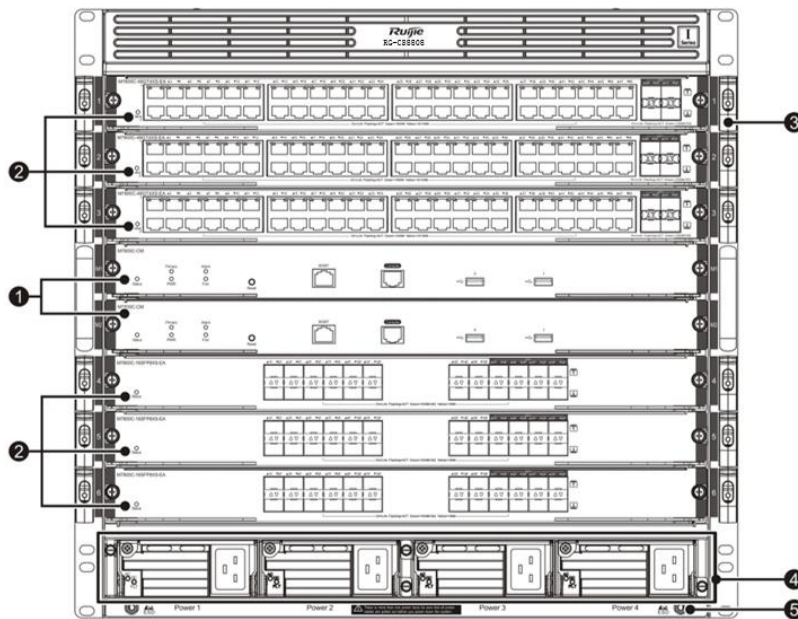

Note:	(1) Supervisor module slots	(4) Slot for system power supply module
	(2) Service module slots	(5) Anti-static wrist strap socket
	(3) Cable management bracket	

⚠ Caution

Ensure the supervisor module, service module, and power supply module are removed from the chassis before you move or transport the RG-CS88-08 chassis.

Back Panel

The back panel of the RG-CS88-08 switch is shown in [Figure 1-3](#).

Figure 1-3 Back Panel of the RG-CS88-08 Switch

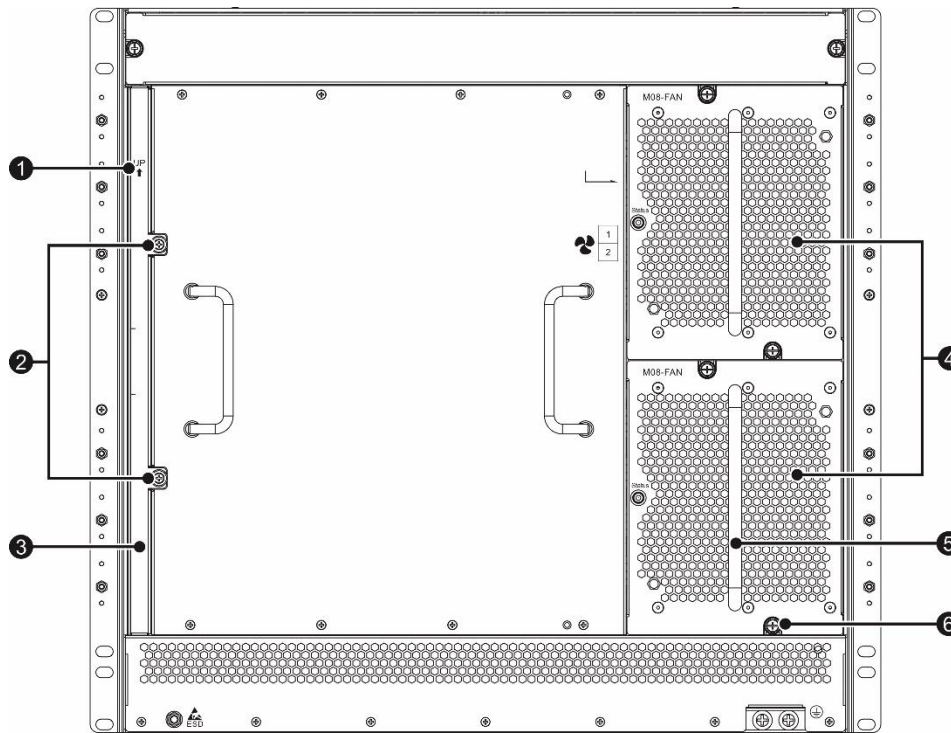

Note:	(1) Direction sign for installing air filter	(4) Fan Tray
	(2) Captive screw of the air filter	(5) Handle of the fan tray
	(3) Air filter module	(6) Captive screws of the fan tray

Power supply

The RG-CS88-08 switch adopts both AC power supply input.

- AC power supply input: The RG-PA1600I-F and the RG-PA600I-F power supply modules are supported. The two types of power supply modules support power management. The supervisor module of the RG-CS88-08 switch can read the power supply information and implement flexible and intelligent power management.

Note

The RG-CS88-08 switch supports N+N power supply redundancy to improve the system stability and reliability. We recommend users to configure N+M redundancy for power supply modules.

Heat Dissipation System

The operating environment temperature of the RG-CS88-08 switch ranges between 0 and 50°C. The thermal design must satisfy the requirement on the device's reliability in the temperature range while ensuring the device's safety and maintainability. According to the thermal design of the RG-CS88-08 switch, fans are used to draw air for forced convection cooling in order to ensure that the device works properly in the specified environment.

Figure 1-4 Ventilation and Heat Dissipation System of the RG-CS88-08 Switch (Air Intakes)

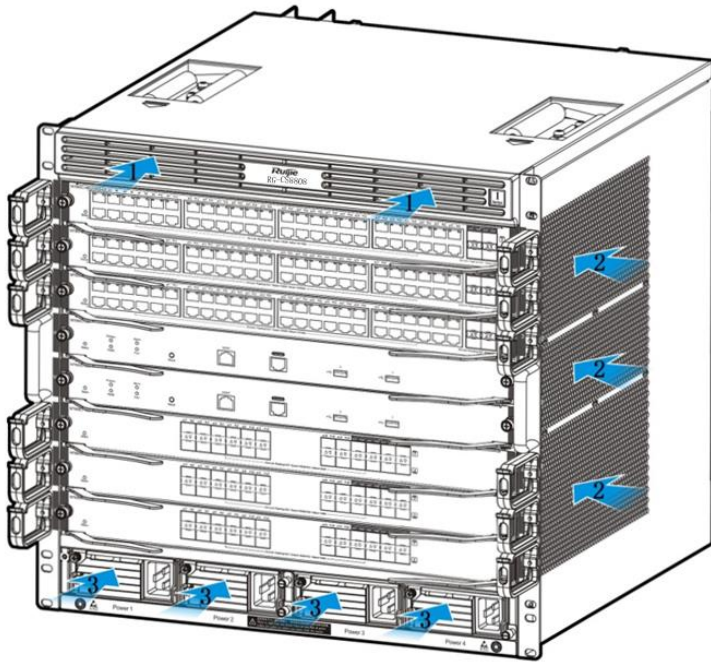

Note:	(1) Air inlet for supervisor modules and switch fabric modules (2) Air intakes for service and supervisor modules	(3) Air intakes for system power modules
-------	--	--

Figure 1-5 Ventilation and Heat Dissipation System of the RG-CS88-08 Switch (Exhaust Vents)

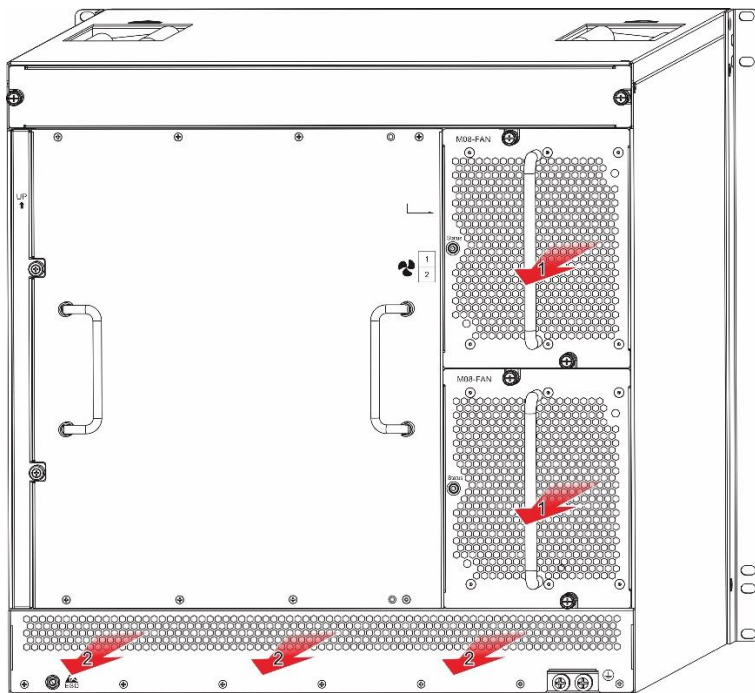

Note:	(1) Exhaust vents for service and supervisor modules	(2) Exhaust vents for system power modules
-------	--	--

For the supervisor and service modules, air flows across the chassis from the right intakes to the back vents.
 For the power supply modules, air flows in from the front intakes and out from the back vents.

- Note**
- The chassis should be mounted in a place with sufficient space for air circulation. Maintain a minimum clearance of 10cm around the chassis.
 - If any module slot is unoccupied, install a filler panel to ensure proper airflow.

1.1.3 Package Contents

Item	RG-CS88-08
Chassis	1
M08-FAN	2
Chutes	12
M3*10 screw	14 (two redundant spares)
M6*16 screw	10 (two redundant spares)
M6 Cage nut	10 (two redundant spares)
Antistatic wrist strap	1
Kelly earth wire external member	1
<i>Network Product Warranty Manual & Hazardous Substance Content Statement (50 years)</i>	1
Ruijie Networks Backbone Product Management Software BMS	1 (pre-installed)

Note

A normal delivery should contain the above mentioned items, which may differ from the actual delivery, depending on purchase contracts. Please check your goods carefully according to the packing list or purchase contract. If you have any questions or there are any errors, please contact your distributor.

1.2 Supervisor Modules

1.2.1 CM88-CM

CM88-CM is the supervisor module of the RG-CS88-08 series switches and is designed with management and switching functions.

Module Appearance

Figure 1-6 Appearance of the CM88-CM Module

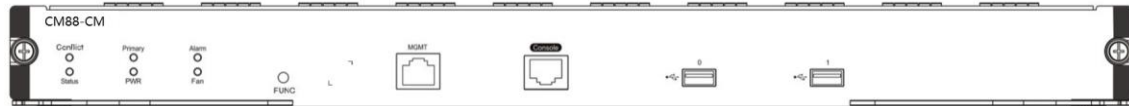

External Port

The CM88-CM module provides three external ports:

- Universal Serial Bus (USB) port: By connecting to the USB port, the USB storage devices can store logs, host version, alarms and other diagnosis information, facilitating online upgrade of switch software and storage of logs.

i Note

To secure data and prevent damage to the device, it is recommended to use high-quality flash disks produced by reliable manufacturers. The USB port is compatible with most USB controllers but may be unable to identify some USB disk models.

- Console port: As a serial communications port, it uses the RS-232 interface level and standard RJ-45 connector. This port is used to connect the device to serial ports of background terminal computers to perform tasks including system commissioning, configuration, maintenance, management, and host software loading.
- 10/100/1000M MGMT port: As the 10/100/1000BASE-T Ethernet port, it uses the RJ-45 connector. This port can be used to connect the device to the Ethernet port of the background computer to load programs. Use the standard cable to connect the device to the Ethernet port of the background computer.

Button

The CM88-CM module provides a FUNC button, which is used to reset the system. If the button is held for less than five seconds, it is a short press; if the button is held for five seconds or longer, it is a long press.

i Note

- In case of a short press, the Status LED flashes in green, and the device resets within five seconds after the press. In case of a long press, the Status LED flashes in green and then flashes in red; the device resets within five seconds after the press.
 - Press the button, and the system starts to collect information, during which the device will not restart. After the collection is complete, the device restarts automatically. Hold the button for a while and release it, the device restarts automatically in five seconds.
-

LED

LED	Identification on the panel	Status	Meaning
Conflict status LED	Conflict	Off	Modules installed in the chassis are compatible with no conflicts.
		Solid yellow	Modules installed in the chassis are incompatible, causing a conflict.
System status LED	Status	Off	The module is powered off.
		Solid red	The module is faulty.
		Blinking green	Initialization is in progress. Continuous blinking indicates errors.
		Solid green	The module is operational.
Primary status LED	Primary	Off	The module acts as the standby supervisor module.
		Solid green	The module acts as the primary supervisor module.
Alarm status LED	Alarm	Off	No fault
		Solid red	The whole system or a module fails to work. The device may be damaged if it continues operating.
		Solid yellow	The temperature exceeds the threshold but the system continues operating.
Fan status LED	FAN	Solid green	The fan is operational.
		Solid yellow	The fan is NOT in the position.
		Solid red	The fan is faulty.
Power status LED	PWR	Off	The power supply module is NOT in the position.
		Solid green	The power supply module is operational.
		Solid red	The power supply module is faulty.
MGMT port LED	MGMT	Off	The MGMT port is NOT connected.
		Green	The MGMT port is connected at 1000Mbps.

LED	Identification on the panel	Status	Meaning
		Yellow	The MGMT port is connected at 10/100Mbps.
		Blinking	The MGMT port is transmitting or receiving data.

Specifications

Model	CM88-CM
CPU	Quad-core CPU, each core with the clock speed of 1.5GHz
BootROM	16 MB (2 flash chips for 1+1 boot redundancy)
Flash memory	8 GB
Memory	DDR4 4GB
Module management port	1 x RJ45 console port 1 x RJ45 MGMT port
USB	2 x USB 2.0 ports (No capacity limit. The 2G/4G/8G/16G/32G capacity is tested.)
Button	1 x FUNC button
Status LED	1 x conflict status LED 1 x system status LED 1 x primary status LED 1 x power status LED 1 x alarm status LED 1 x fan status LED 2 x MGMT port LEDs (indicating the same status information)
Module power Consumption	< 50 W
Module dimensions (W x D x H)	438.5 mm x 309.0 mm x 40.1 mm (17.26 in. x 12.17 in. x 1.58 in.)
Module weight	2.1 kg (4.63 lbs)
Mean time between failure (MTBF)	960,000 hours (about 109 years)
Module hot swapping	Supported
USB hot swapping	Supported

⚠ Caution

The CM88-CM adopts the CR2032 lithium battery. The device may explode if a wrong battery model is used. Used batteries should be properly disposed of.

1.2.2 Package Contents

Item	CM88-CM
Supervisor module	1
<i>Network Product Warranty Manual & Hazardous Substance Content Statement (20 years)</i>	1
Console cable	1

1.3 Switch Fabric Modules

The RG-CS88-08 series switches do not support independent switch fabric modules.

1.4 Line Cards

1.4.1 CM88-48GT-H

Module Appearance

Figure 1-7 Appearance of the CM88-48GT-H

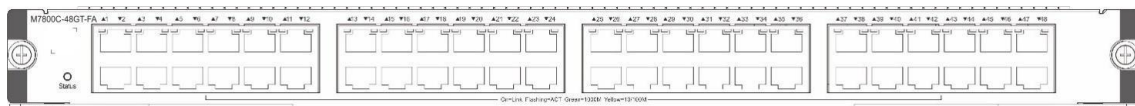

External Port

CM88-48GT-H provides 48 10/100/1000BASE-T RJ45 ports. The RJ45 ports support 10/100/1000Mbps auto-negotiation.

LED

LED	Identification on the panel	Status	Meaning
System status LED	Status	Off	The module is powered off.
		Solid red	The module is faulty.
		Blinking green	Initialization is in progress. Continuous blinking indicates errors.

LED	Identification on the panel	Status	Meaning
		Solid green	The module is operational.
10/100/1000BASE-T port LED	Link/ACT	Off	The port link is NOT connected.
		Solid green	The port is connected at 1000Mbps.
		Solid yellow	The port is connected at 10Mbps or 100Mbps.
		Blinking	The port is transmitting and receiving data.

Specifications

Model	CM88-48GT-H
CPU	Quad-core CPU, each core with the clock speed of 1.5GHz
BootROM	16 MB (2 flash chips for 1+1 boot redundancy)
Flash memory	8 GB
Memory	DDR4 2GB
Switch buffer	8 MB
Module service port	48 x 10/100/1000BASE-T ports
Transmission medium	10/100/1000BASE-T Cat 5 UTP
Status LED	1 x system status LED 48 x 10/100/1000BASE-T port LEDs
Module power consumption	< 75 W
Module dimensions (W x D x H)	412 mm x 390 mm x 40.16 mm (16.22 in. x 15.35 in. x 1.58 in.)
Module weight	3.1 kg (6.83 lbs)
Mean time between failure (MTBF)	334,000 hours (about 38 years)
Module hot swapping	Supported
Cable hot swapping	Supported

1.4.2 CM88-48SFP-H

Module Appearance

Figure 1-8 Appearance of the CM88-48SFP-H

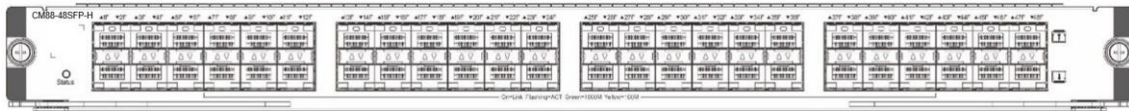

External Port

CM88-48SFP-H provides 48 SFP ports. The SFP ports support 100/1000Mbps auto-negotiation.

LED

LED	Identification on the panel	Status	Meaning
System status LED	Status	Off	The module is powered off.
		Solid red	The module is faulty.
		Blinking green	Initialization is in progress. Continuous blinking indicates errors.
		Solid green	The module is operational.
1GE SFP port LED	Link/ACT	Off	The port link is NOT connected.
		Solid green	The port is connected at 1000Mbps.
		Solid yellow	The port is connected at 100Mbps.
		Blinking	The port is transmitting and receiving data.

Specifications

Model	CM88-48SFP-H
CPU	Quad-core CPU, each core with the clock speed of 1.5GHz
BootROM	16 MB (2 flash chips for 1+1 boot redundancy)
Flash memory	8 GB
Memory	DDR4 2GB
Switch buffer	8 MB
Module service port	48 x 1GE SFP ports
Transmission medium	100BASE-LX (1310 nm) 100BASE-LH (1310 nm, 1550 nm) 1000BASE-SX (850 nm) 1000BASE-LX (1310 nm)

	1000BASE-LH (1310 nm) 1000BASE-ZX (1550 nm) 1000BASE-LX (1310 nm, 1550 nm) 1000BASE-LH (1310 nm, 1550 nm)
Status LED	1 x system status LED 48 x 1GE SFP port LEDs
Module power consumption	< 95 W
Module dimensions (W x D x H)	412 mm x 390 mm x 40.16 mm (16.22 in. x 15.35 in. x 1.58 in.)
Module weight	3.2 kg (7.05 lbs)
Mean time between failure (MTBF)	329,000 hours (about 37 years)
Module hot swapping	Supported
Cable hot swapping	Supported

1.4.3 CM88-48XS-H

Module Appearance

Figure 1-9 Appearance of the CM88-48XS-H

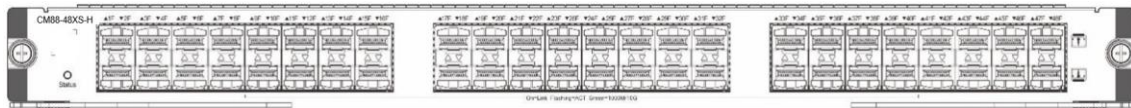

External Port

CM88-48XS-H provides 48 SFP+ ports. The SFP+ ports support 10G SFP+ modules, 1 Gigabit SFP modules and hot swapping.

Note

The CM88-48XS-H module supports 10G SFP+ module and 1 Gigabit SFP module. 10G SFP+ module cannot be used as a 1 Gigabit SFP module. If the 1 Gigabit SFP module is used, force the interface to run at the specified speed, duplex mode and flow control.

LED

LED	Identification on the panel	Status	Meaning
System status	Status	Off	The module is powered off.

LED		Solid red	The module is faulty.
		Blinking green	Initialization is in progress. Continuous blinking indicates errors.
		Solid green	The module is operational.
1GE SFP port LED	Link/ACT	Off	The port link is NOT connected.
		Solid green	The port is connected at 1000Mbps.
		Solid yellow	The port is connected at 100Mbps.
		Blinking	The port is transmitting and receiving data.
10GE SFP+ port LED	Link/ACT	Off	The port link is NOT connected.
		Solid green	The port is connected.
		Blinking	The port is transmitting and receiving data.

Specifications

Model	CM88-48XS-H
CPU	Quad-core CPU, each core with the clock speed of 1.5GHz
BootROM	16 MB (2 flash chips for 1+1 boot redundancy)
Flash memory	8 GB
Memory	DDR4 2GB
Switch buffer	32 MB
Module service port	48 x 1GE/10GE SFP+ ports
Transmission medium	1000BASE-SX (850 nm) 1000BASE-LX (1310 nm) 1000BASE-LH (1310 nm) 1000BASE-ZX (1550 nm) 1000BASE-LX (1310 nm, 1550 nm) 1000BASE-LH (1310 nm, 1550 nm) 10GBASE-SR (850 nm) 10GBASE-LR (1310 nm) 10GBASE-ER (1550 nm) 10GBASE-ZR (1550 nm) 10GBASE SFP+ active optical cable (AOC)

Status LED	1 x system status LED 48 x 1GE/10GE SFP+ port LEDs
Module power consumption	< 160 W
Module dimensions (W x D x H)	412 mm x 390 mm x 40.16 mm (16.22 in. x 15.35 in. x 1.58 in.)
Module weight	3.85 kg (8.49 lbs)
Mean time between failure (MTBF)	305,000 hours (about 34 years)
Module hot swapping	Supported
Cable hot swapping	Supported

1.4.4 CM88-8CQ-H

Module Appearance

Figure 1-10 Appearance of the CM88-8CQ-H

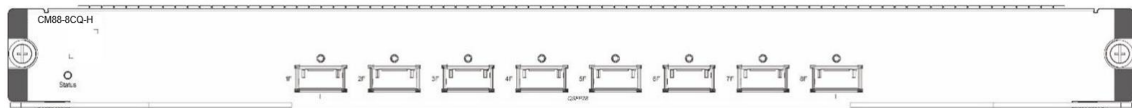

External Port

CM88-8CQ-H provides eight QSFP28 ports. The QSFP28 ports support 100G QSFP28 modules, 40G SFP28 modules and hot swapping.

LED

LED	Identification on the panel	Status	Meaning
System status LED	Status	Off	The module is powered off.
		Solid red	The module is faulty.
		Blinking green	Initialization is in progress. Continuous blinking indicates errors.
		Solid green	The module is operational.
40GE/100GE QSFP28 port LED	Link/ACT	Off	The port link is NOT connected.
		Solid green	The port is connected.
		Blinking	The port is transmitting and receiving data.

Specifications

Model	CM88-8CQ-H
CPU	Quad-core CPU, each core with the clock speed of 1.5GHz
BootROM	16 MB (2 flash chips for 1+1 boot redundancy)
Flash memory	8 GB
Memory	DDR4 2GB
Switch buffer	32 MB
Module service port	8 x 40GE/100GE QSFP28 ports. The QSFP28 port cannot be split into four 25G ports or four 10G ports.
Transmission medium	40GBASE-SR (850 nm) 40GBASE-LSR (850 nm) 40GBASE-LR4 (1310 nm) 40GBASE-iLR4 (1310 nm) 40GBASE-LX4 (1310 nm) 40GBASE-QSFP+ active optical-cable (AOC) 100GBASE-SR (850 nm) 100GBASE-LR4 (1310 nm) 100GBASE-iLR4 (1310 nm) 100GBASE QSFP28 active optical-cable (AOC)
Status LED	1 x system status LED 8 x 40GE/100GE QSFP28 port LEDs
Module power consumption	< 130 W
Module dimensions (W x D x H)	412 mm x 390 mm x 40.16 mm (16.22 in. x 15.35 in. x 1.58 in.)
Module weight	3.5 kg (7.72 lbs)
Mean time between failure (MTBF)	335,000 hours (about 38 years)
Module hot swapping	Supported
Cable hot swapping	Supported

1.4.5 Package Contents

Item	CM88-48GT-H	CM88-48SFP-H
	CM88-48XS-H	CM88-8CQ-H
Line Card	1	
<i>Network Product Warranty Manual & Hazardous Substance Content Statement (20 years)</i>	1	
Protective Box	1	
Protective Box Installation And Remove Instruction	1	

1.5 Power Modules

1.5.1 RG-PA600I-F

Module Appearance

Figure 1-11 Appearance of the RG-PA600I-F Module

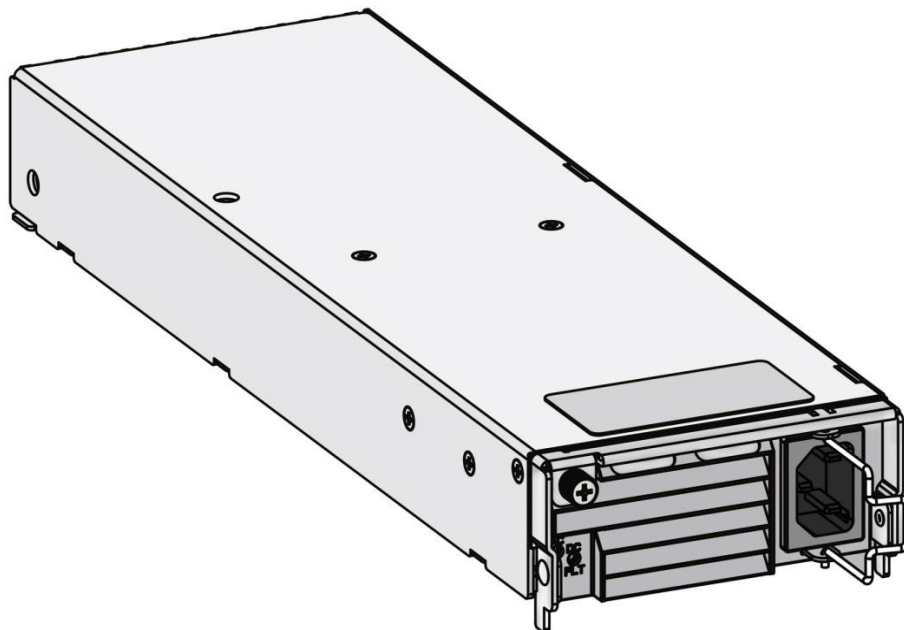

External Port

The RG-PA600I-F module provides 12 VAC input to the overall system of the RG-CS88-08 switch. The front panel of the power supply module provides a 3-pin plug, which can be connected to a standard 10A power cord.

LED

LED		Meaning
AC	DC/FLT	
Solid green	Solid green	The module is operational
Off	Solid red	There is no power input or input undervoltage.
Solid green	Solid red	Overvoltage
Solid green	Solid red	Overcurrent
Solid green	Solid orange	Temperature alarm
Solid green	Solid red	Over-temperature fault
Solid green	Solid red	PSR on/off

Specifications

Model	RG-PA600I-F
Power input	AC input: <ul style="list-style-type: none"> ● Rated input voltage: 100 V AC to 240 V AC, 50 Hz to 60 Hz ● Maximum input voltage: 90 V AC to 264 V AC, 47 Hz to 63 Hz ● Maximum input current: 10 A
Power output	12V DC, 0 A to 50 A Standby: 5 V DC, 0 A to 2 A
Maximum output power	600 W
Leakage current	≤ 0.85 mA
Power cord	10 A power cord
Weight of power module	1.64 kg (3.62 lbs)
Altitude	Operating altitude: 5,000 m (16404.20 ft.) max Storage altitude: 5,000 m (16404.20 ft.) max

Note

When you plug the power cable into the power supply, pull down the retention clip over the plug on the power cable.

1.5.2 RG-PA1600I-F

Module Appearance

Figure 1-12 Appearance of the RG-PA1600I-F Module

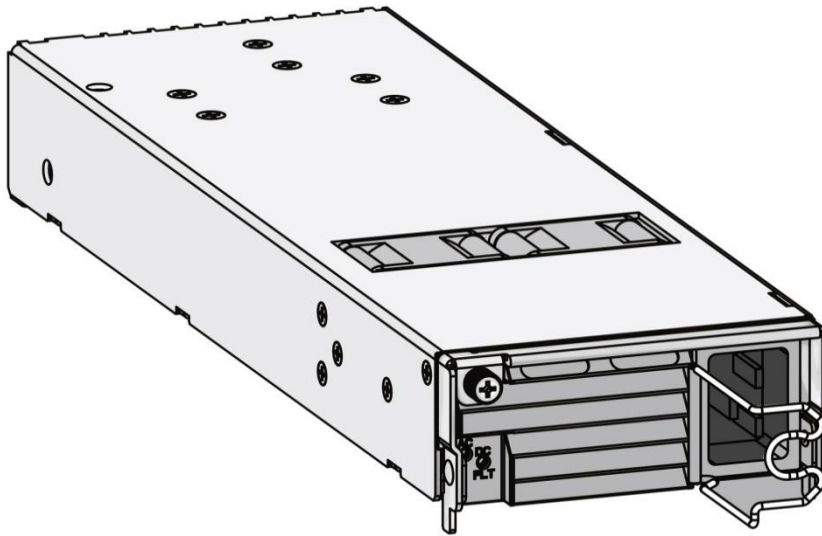

External port

The RG-PA1600I-F module provides 12 VAC input to the overall system of the RG-CS88-08 switch. The front panel of the power supply module provides a 3-pin plug, which can be connected to standard 16A power cord.

LED

LED		Meaning
AC	DC/FLT	
Solid green	Solid green	The module is operational
Off	Solid red	There is no power input or input undervoltage.
Solid green	Solid red	Overvoltage.
Solid green	Solid red	Overcurrent.
Solid green	Solid orange	Temperature alarm
Solid green	Solid red	Over-temperature fault
Solid green	Solid red	PSR on/off

Specifications

Model	RG-PA1600I-F
Power input	AC input: <ul style="list-style-type: none"> ● Rated input voltage: 100 V AC to 240 V AC, 50 Hz to 60 Hz ● Maximum input voltage: 90 V AC to 264 V AC, 47 Hz to 63 Hz ● Maximum input current: 16 A

Power output	100 V AC to 176 V AC: 12 V DC, 100 A max 176 V AC to 240 V AC: 12 V DC, 133.4 A max Standby: 5 V DC, 2 A max
Maximum output power	100 V AC to 176 V AC: 1200 W 176 V AC to 240 V AC: 1600 W
Leakage current	≤ 3 mA
Power cord	16 A power cord
Weight of power module	2.04 kg (4.50 lbs)
Altitude	Operating altitude: 5,000 m (16404.20 ft.) max Storage altitude: 5,000 m (16404.20 ft.) max

Note

When you plug the power cable into the power supply, pull down the retention clip over the plug on the power cable.

1.6 Fan Modules

1.6.1 M08-FAN

Module Appearance

Figure 1-13 Appearance of the M08-FAN Module

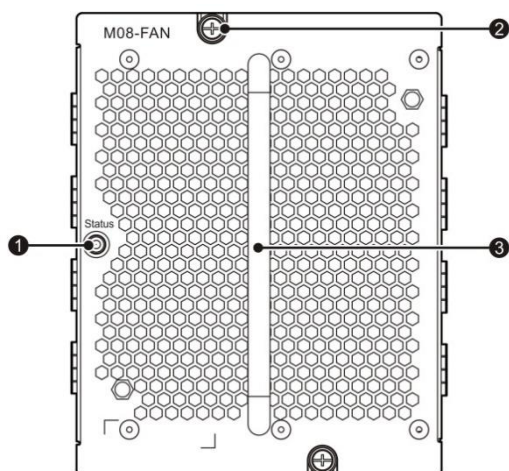

Note:	(1) Fan status LED (2) Captive screws of fan tray	(3) Fan handle
--------------	--	----------------

Composition

The M08-FAN is the fan for service modules and supervisor modules on the RG-CS88-08. There is one M08-FAN tray with two fans and one fan control board. The M08-FAN draws air out to form convection for heat dissipation.

Specifications

Model	M08-FAN
Module dimensions (W x D x H)	167.5 mm x 132 mm x 133 mm (6.60 in. x 5.20 in. x 5.24 in.)

LED

LED	Status	Meaning
Status	Off	The fan is not powered on.
	Solid green	The fan is operational.

Features

Function	Meaning
Fan monitoring	Rotational speed monitoring, failure alarm Speed-adjustment controlled by temperature
Fan module hot swapping	Supported

1.6.2 Package Contents

Item	M08-FAN
Fan module	1
<i>Network Product Warranty Manual & Hazardous Substance Content Statement (20 years)</i>	1

1.7 Pluggable Modules

The following table describes the compatibility between switches and optical transceivers.

For more information, visit Ruijie Networks official website at <https://www.ruijienetworks.com/>. Choose **Support > Documentation and Download > Products > Switches > Accessories > Optics and Transceivers**. Click on the optical transceiver model to access related documents, or use keywords to search for required documents.

Models	Matching Optical Transceivers
CM88-48SFP-H <ul style="list-style-type: none"> ● 48 x 1GE SFP ports CM88-48XS-H <ul style="list-style-type: none"> ● 48 x 1GE/10GE SFP+ ports 	1GE optical transceivers <ul style="list-style-type: none"> ● Mini-GBIC-GT ● MINI-GBIC-SX-MM850 ● MINI-GBIC-LX-SM1310 ● MINI-GBIC-LH40-SM1310 ● MINI-GBIC-ZX80-SM1550 ● GE-SFP-LX20-SM1310-BIDI ● GE-SFP-LX20-SM1550-BIDI ● GE-SFP-LH40-SM1310-BIDI ● GE-SFP-LH40-SM1550-BIDI
CM88-48XS-H <ul style="list-style-type: none"> ● 48 x 1GE/10GE SFP+ ports 	10GE optical transceivers and cables <ul style="list-style-type: none"> ● XG-SFP-SR-MM850 ● XG-SFP-LR-SM1310 ● XG-SFP-ER-SM1550 ● XG-SFP-AOC1M ● XG-SFP-AOC3M ● XG-SFP-AOC5M
CM88-8CQ-H <ul style="list-style-type: none"> ● 8 x 40GE/100GE QSFP28 ports 	40GE optical transceivers and cables <ul style="list-style-type: none"> ● 40G-QSFP-SR-MM850 ● 40G-QSFP-LSR-MM850 ● 40G-QSFP-LR4-SM1310 ● 40G-QSFP-iLR4-SM1310 ● 40G-QSFP-LX4-SM1310 ● 40G-AOC-5M ● 40G-AOC-30M 100GE optical transceivers and cables <ul style="list-style-type: none"> ● 100G-QSFP-SR-MM850 ● 100G-QSFP-LR4-SM1310 ● 100G-QSFP-iLR4-SM1310 ● 100G-AOC-5M ● 100G-AOC-10M

 **Caution**

Use pluggable modules supplied by Ruijie Networks. The reliability of modules supplied by other vendors cannot be guaranteed, which may cause service instability. If you use a module supplied by other vendors, Ruijie Networks will not be liable for the service issues and will not solve them in principle.

2 Preparation before Installation

2.1 Safety Suggestions

Note

- To avoid body injury and equipment damage, please carefully read the safety suggestions before you install RG-CS88-08.
 - The following safety suggestions do not cover all possible dangers.
-

2.1.1 General Suggestions

- Take security measures (such as wearing an anti-static wrist strap) to ensure safety.
- Keep the chassis clean, free from any dust. Please do not place the switch at a damp place to prevent the moisture from entering the switch.
- Make sure the installation site is dry and flat. Take skid-proof measures.
- Do not place the equipment in a walking area.
- Do not wear loose clothes or any other things that may be caught by the chassis during installation and maintenance.
- Moving or lifting the switch and its components requires team work. Be careful not to get hurt.

2.1.2 Safety Precautions for Removal

RG-CS88-08 is large and heavy. When you handle them, please pay attention to the following requirements:

- Avoid moving the equipment frequently.
- Turn off all power supplies and unplug all power cables before you remove the equipment.
- At least four people are needed to move the equipment. Do not attempt to move the equipment by one person only.
- Keep balance when moving the equipment, and avoid injuring your leg and feet or spraining your waist.

Caution

- Do not move the equipment by grasping the panel, power supply handle, ventilation holes of the chassis, as they are not designed to bear the weight of the entire equipment. This may cause damage or even injure you.
 - Remove all supervisor modules, service modules and power modules before you move the device, to reduce the chassis weight.
 - The device must be installed and used in the restricted access location.
-

2.1.3 Electrical Safety

- Please observe local regulations and specifications when performing electrical operations. Relevant operators must be qualified.
- Please carefully check for any potential danger in the working area, for example, ungrounded power supply,

unreliable grounding of the power supply and damp/wet ground or floor.

- Find out the location of the emergency power supply switch in the room before installation. First cut off the power supply in case of an accident.
- Be sure to make a careful check before you shut down the power supply.
- Do not place the equipment in a damp/wet location. Do not let any liquid enter the chassis

 **Caution**

- Any nonstandard and inaccurate electrical operation can cause an accident such as fire or electrical attack, thus causing severe even fatal damages to human bodies and equipment.
 - Direct or indirect touch through a wet object on high-voltage and mains supply can bring a fatal danger.
-

2.1.4 Static Discharge Damage Prevention

Although much has been done in RG-CS88-08 to prevent static electricity, great damage may be caused to the circuitry and equipment when the static electricity exceeds a certain limit. In the communication network of the RG-CS88-08, electrostatic induction may come from the following sources: External electric field produced by the high-voltage supply cable, lightning, etc; internal systems such as the indoor floor and the entire structure.

To prevent damage from static electricity, you must pay attention to the following:

- Properly ground the equipment.
- Take dust prevention measures in the room.
- Maintain an appropriate humidity.
- Always wear an anti-static wrist strap when you touch any circuit board.
- Try to hold a circuit board by its edges. Do not touch any components or the PCB.
- Use an anti-static shielding bag to properly store the board.
- Do not let any clothes touch a circuit board. An antistatic wrist strap can only prevent human static electricity from damaging the circuit board, but cannot prevent any static electricity on clothes.

 **Caution**

The CS88-08 series switches are equipped with an anti-static wrist strap. Please refer to [Figure 2-1](#) for the position of the jack for the wrist strap.

The CS88-08 series switches are equipped with an anti-static wrist strap. To protect electronic components against static electricity, wear an anti-static wrist strap close to your skin and keep it properly grounded while installing swappable modules.

Use an anti-static wrist strap as follows:

- (1) Ensure that the switch is properly grounded.
- (2) Put your hand in the anti-static wrist strap.
- (3) Tighten the buckle till the trap is closely attached to your skin.

 **Caution**

- For safety, use a multimeter to measure the resistance between yourself and the ground, which should be within the range from 1 to 10 Ω .
-

- Make sure that the switch is properly grounded when the anti-static wrist strap is connected to the ground through the chassis jack.

Figure 2-1 Preventing EMI on RG-CS88-08

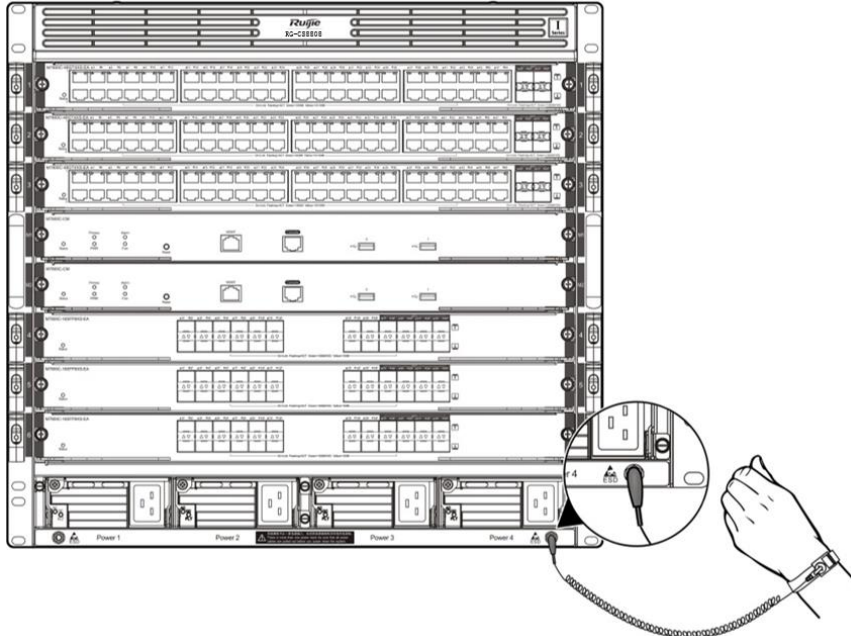

2.1.5 Laser Safety

Among the modules supported by RG-CS88-08, there are a great number of optical modules that are Class I laser products.

Precautions:

- When a fiber transceiver works, ensure that the port has been connected with a fiber or is covered with a dust cap so as to keep out dust and avoid burning your eyes.
- Do not stare into any fiber port.

⚠ Caution

Do not stare into any fiber port under any circumstances, as this may cause permanent damage to your eyes.

2.2 Installation Site Requirements

RG-CS88-08 must be used in the room. To ensure normal operation and a prolonged useful life of the equipment, the installation site must meet the following requirements.

2.2.1 Load Bearing Requirements

Evaluate the load bearing requirements for the ground according to the weight of the switch and its components (such as the cabinet, chassis, single board and power supply). Make sure the installation site meet the requirements.

2.2.2 Space Requirements

- It is recommended that the width of the machine room corridor be greater than 0.8m to ensure enough space for moving of chassis and plugging and removing of modules.
- Please do not install the switch against the wall. Instead, please leave some space around the switch for heat dissipation and switch maintenance.

2.2.3 Ventilation Requirements

See *Product Overview* for heat dissipation and ventilation. Maintain a minimum clearance of 10 cm around the air intakes and exhaust vents for ventilation. After connecting various cables, you should bundle the cables or place them in the cable management bracket to avoid blocking air intakes.

Caution

Remove all foam packaging materials and protective plastics before you power on the switch.

2.2.4 Temperature Requirements

To ensure the normal operation and a prolonged useful life of the RG-CS88-08, you must maintain an appropriate temperature in the equipment room. Too high or low temperature for a long period of time may damage the equipment.

- In an environment with high temperature, the equipment is subjected to even greater harm, as its performance may degrade significantly and its useful life may be shortened in the case of long-term exposure that expedites the aging process.

Temperature Requirements of the RG-CS88-08

Operating Temperature	Storage Temperature
0°C to 50°C	-40°C to 70°C

Note

The ambient temperature is measured at the point that is 1.5m above the floor and 0.4m before the equipment when there is no protective plate in front or back of the equipment rack.

RG-CS88-08 Dusting Cycle Suggestions:

- (1) Clean the air filters every three months.
- (2) Dust the air intakes and exhaust vents of all modules every three months.
- (3) Dust the modules every one or two years.
- (4) Dust the fan shelves yearly.
- (5) Dust the chassis, including the backplane, every one or two years.

Note

Dust the equipment more often if the equipment room does not have enough dust-proof measures.

2.2.5 Humidity Requirements

To ensure the normal operation and a prolonged use life of the RG-CS88-08, you must maintain an appropriate humidity in the equipment room. Too high or low humidity for a long period of time may damage the equipment.

- In an environment with high relative humidity, the insulating material may have bad insulation or even leak electricity, and sometimes the materials may suffer from mechanical performance change and metallic parts may get rusted.
- On the other hand, in an environment with low relative humidity, the insulating strip may dry and shrink, and static electricity may occur easily and endanger the circuit on the equipment.
- Humidity Requirements of the RG-CS88-08

Operating Humidity	Storage Humidity
10% to 90% (non-condensing)	5% to 95% (non-condensing)

Note

The ambient humidity is measured at the point that is 1.5m above the floor and 0.4m before the equipment when there is no protective plate in front or back of the equipment rack.

2.2.6 Cleanness Requirements

Dust poses the top threat to the running of the equipment. The indoor dust falling on the equipment may be adhered by the static electricity, causing bad contact of the metallic joint. Such electrostatic adherence may occur more easily when the relative humidity is low, not only affecting the use life of the equipment, but also causing communication faults. The following table shows the requirements for the dust content and granularity in the equipment room.

Substance	Concentration Limit (particles/m ³)
Dust particles (diameter $\geq 0.5\mu\text{m}$)	$\leq 3.5 \times 10^6$
Dust particles (diameter $\geq 5\mu\text{m}$)	$\leq 3 \times 10^4$

Note

The air filter of the RG-CS88-08 must be cleaned at interval to ensure good ventilation and dust prevention.

Apart from dust, the salt, acid and sulfide in the air in the equipment room must also meet strict requirements; as such poisonous substances may accelerate the corrosion of the metal and the aging of some parts. The equipment room should be protected from the intrusion of harmful gases (for example, SO₂, H₂S, NO₂ and Cl₂), whose requirements are listed in the following table.

Gas	Average (mg/m ³)	Maximum (mg/m ³)
SO ₂	0.3	1.0
H ₂ S	0.1	0.5
NO ₂	0.5	1.0
Cl ₂	0.1	0.3

 **Note**

The **Average** refers to the average limit of harmful gas in one week. The **Maximum** value is the upper limit of the harmful gas measured in one week for up to 30 minutes every day.

2.2.7 Power Requirements

AC power supply:

- RG-PA1600I-F and RG-PA600I-F power modules adopt 90 to 264 VAC/ 47 to 63 Hz input.

The following table lists the power consumption of each module:

RG-CS88-08 Series Modules	Maximum Power Consumption (W)
M08-FAN	88
CM88-CM	50
CM88-48GT-H	75
CM88-48SFP-H	95
CM88-48XS-H	160
CM88-8CQ-H	130

 **Caution**

- The RG-CS88-08 provides N+N redundancy of power supply. You are recommended to use multiple power supplies for the equipment to ensure its continuous and stable operation by avoiding the impact of unexpected power failures on the equipment.
- When the dual power supply is applied, the type of the power supply should be identical.
- If a power supply system is equipped with a leakage protector (also referred to as "leakage current switch" or "leakage current breaker"), the rated leakage action current of each leakage protector is greater than twice of the theoretical maximum leakage current of all the power supplies in the system. For example, if a system is equipped with eight identical power supplies, the leakage current of each power supply is equal to or less than 3 mA, and the leakage current of the system totals 24 mA. A leakage protector with 30 mA rated action current supports less than five power supplies (that is, Action current of the leakage protector/2/Maximum leakage current of each power supply = 30/2/3 = 5). In other words, the leakage protector with 30 mA rated action current supports no more than four power supplies. In this case, the eight power supplies in the system require at least two leakage protectors with 30 mA

rated action current and each leakage protector supports four power supplies. If power supplies in a system differ in models, the rated leakage action current of each leakage protector divided by two is greater than the sum of maximum leakage currents of all the power supplies. The rated leakage non-action current of a leakage protector shall be 50% of the leakage action current. Take a leakage protector with 30 mA rated leakage action current as an example. The rated leakage non-action current shall be 15 mA. When the leakage current is below 15 mA, the protector shall not act. Otherwise, misoperation may easily occur due to high sensitivity and thus the leakage protector trips, devices are powered off, and services are interrupted.

- To guarantee personal safety, the rated leakage action current of each leakage protector in the system must be equal to or less than 30 mA (human body safety current is 30 mA). When twice of the total leakage current of the system is greater than 30 mA, the system must be equipped with two or more leakage protectors.
 - For the leakage current value of each power supply model, see the power supply model parameter table in Chapter 1.
-

2.2.8 System Grounding Requirements

A good grounding system is the basis for the stable and reliable operation of the RG-CS88-08. It is the key to prevent lightning stroke and resist interference. Please carefully check the grounding conditions on the installation site according to the grounding requirements, and perform grounding properly as needed.

Safety Grounding

The equipment using AC power supply must be grounded by using the yellow/green safety grounding cable. Otherwise, when the insulating resistance decreases the power supply and the enclosure in the equipment, electric shock may occur.

Caution

The building installation shall provide a means for connection to protective earth, and the equipment is to be connected to that means.

Lightning Grounding

The lightning protection system of the facility is a separate system that consists of the lightning rod, down lead conductor and the connector to the grounding system, which usually shares the power reference ground and yellow/green safety cable ground. The lightning discharge ground is for the facility only, irrelevant to the equipment.

Note

For lightning protection, see Appendix Switch Lightning Protection.

EMC Grounding

The ground required for EMC design includes shielding ground, filter ground, noise and interference suppression, and level reference. All the above constitute the comprehensive grounding requirements. The grounding resistance should be less than 1Ω. One grounding point is reserved at the left back of the chassis. The grounding point is pasted with a conspicuous warning label.

2.2.9 EMI Consideration

Various interference sources, from either outside or inside the equipment or application system, affect the system in the conductive ways such as capacitive coupling, inductive coupling, and electromagnetic radiation. There are two types of electromagnetic interferences: radiated interference and conducted interference, depending on the type of the propagation path. When the energy, often RF energy, from a component arrives at a sensitive component via the space, the energy is known as radiated interference. The interference source can be both a part of the interfered system and a completely electrically isolated unit. Conducted interference results from the electromagnetic wire or signal cable connection between the source and the sensitive component, along the cable the interference conducts from one unit to another. Conducted interference often affects the power supply of the equipment, but can be controlled by a filter. Radiated interference may affect any signal path in the equipment, and is difficult to shield.

- Effective measures should be taken for the power system to prevent the interference from the electric grid.
- The working ground of the routers should be properly separated and kept as far as possible from the grounding device of the power equipment or the anti-lightning grounding device.
- Keep the equipment away from high-power radio transmitter, radar transmitting station, and high-frequency large-current device.
- Measures must be taken to isolate static electricity.

2.3 Cabinet Mounting

Make sure the cabinet complies with the following conditions:

- Install the switch in a 19-inch cabinet in 4-post form hold.
- Be sure the distance between two square hole strips, one on each side, is 465 mm.

Figure 2-2 19-inch Cabinet

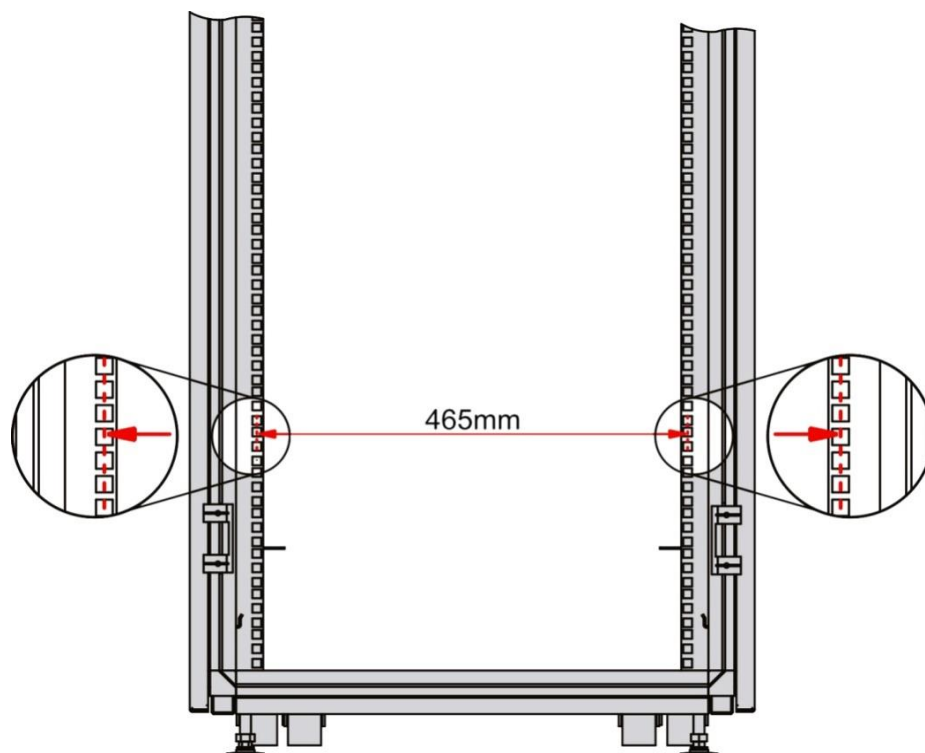

- Be sure that the square hold strip is at least 125 mm far from the outboard front door and the door is at most 25 mm thick to ensure a minimum available distance of 100 mm.
- The front door of the RG-CS88-08 switch is at least 500 mm far from the back door.

Figure 2-3 Cabinet Dimensions

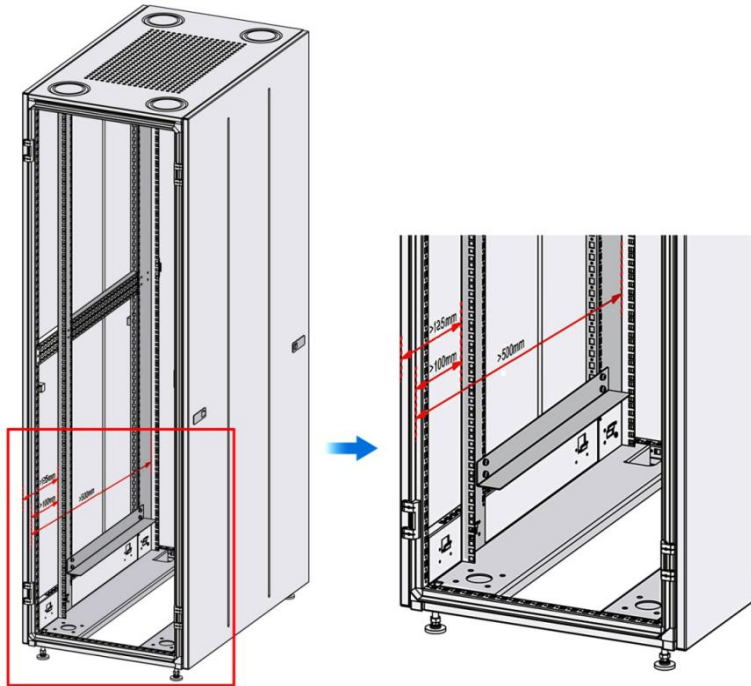

- Be sure that the slide rail in the cabinet is enough to bear the weight of a RG-CS88-08 and its installation accessories.
- Be sure that the cabinet provides an earthing terminal for the switch to be grounded.
- Be sure that the front and back doors of the cabinet have porosities greater than 50% for good ventilation and heat dissipation.

2.4 Installation Tools

Common Tools	Cross screwdriver, straight screwdriver, related electric and optical cables Bolts, diagonal pliers, straps
Special Tools	Anti-static glove, stripping pliers, crimping pliers, crimping pliers for the crystal head, wire cutter
Fiber Optic Cleaning Tools	Air-laid paper, optical fiber microscope
Meter	Multimeter, bit error rate tester (BERT), optical power meter

i Note

The tool kit is customer supplied.

2.5 Precaution for Fiber Connection

Before connecting fiber cables, make sure the model of the optical transceiver and fiber type match the optical port. The transmit port on the local device should be connected to the receive port on the peer device and vice versa.

2.6 Unpacking Requirements

Goods Checklist

Chassis Carton	Device panels are installed and operational. Fans, screwdriver, anti-static wrist strap, yellow/green grounding wires, quick installation guide, packing list
Module Carton	Modules, packing list, documentation

i Note

A normal delivery should contain the above mentioned items, which may differ from the actual delivery, depending on purchase contracts. Please check your goods carefully against the packing list or purchase contract. If you have any questions or there are any errors, please contact your distributor.

3 Product Installation

RG-CS88-08 series Ethernet switch must be used and fixed in the room.

Note

Make sure you have carefully read part 2 and this part, and be sure that the requirements set forth in part 2 have been met.

3.1 Installation Procedure

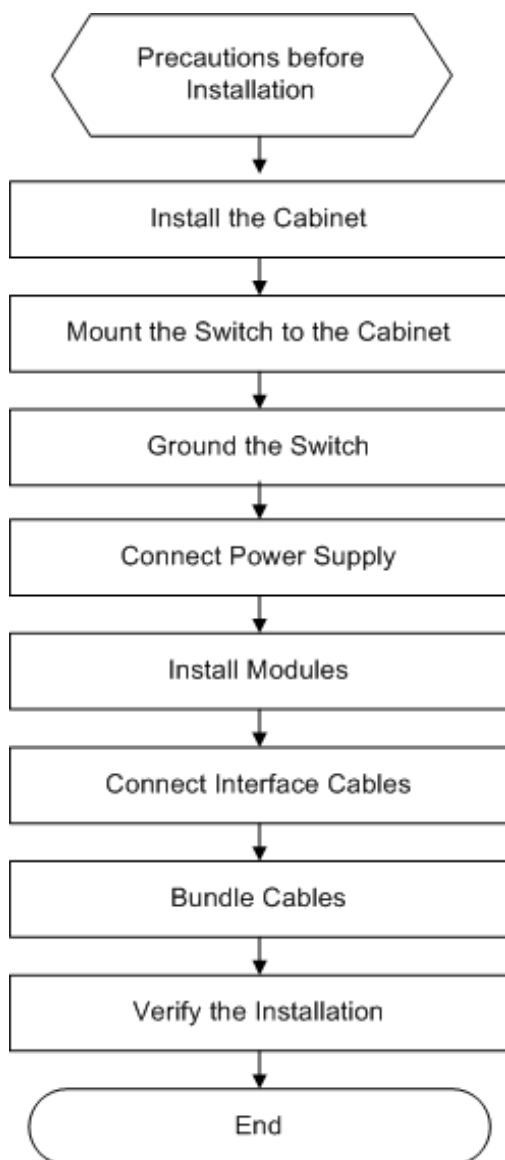

3.2 Installation Verification

The RG-CS88-08 is complicated equipment, so you must carefully plan and arrange the installation location, networking mode, power supply, and wiring before installation. Verify the following before installation:

- The installation location is of a good air flow.
- The installation location meets the temperature and humidity requirements of the equipment.
- The qualified power supply is available at the installation location.
- The related network cables have already been deployed at the installation location.
- The selected power supply meets the system power.

3.3 Installing the Air Filter (Optional)

Install air filters of the supervisor module and service module on the RG-CS88-08.

Caution

If an air filter is used for a long time, dust may block its air vent, weakening system ventilation. It is recommended you clean the air filter every three months.

Installing the Air Filters of the Supervisor Module and Service Module

RG-CS88-08

Figure 3-1 Air Filter Location of the Supervisor Module and Service Module on RG-CS88-08 Switch

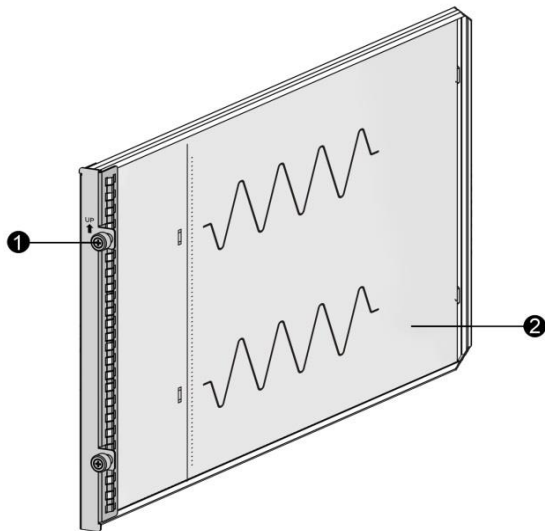

Note:	① Captive screw	② Air filter
-------	-----------------	--------------

- To install the air filter , follow these steps:
 - (1) Insert the air filter along the slide rail. Note the instruction on the air filter to ensure that the air filter is installed properly.

- (2) Tighten the captive screws on the air filter with a screwdriver.

Figure 3-2 Installing the Air Filter of the Supervisor Module and Service Module on RG-CS88-08 Switch

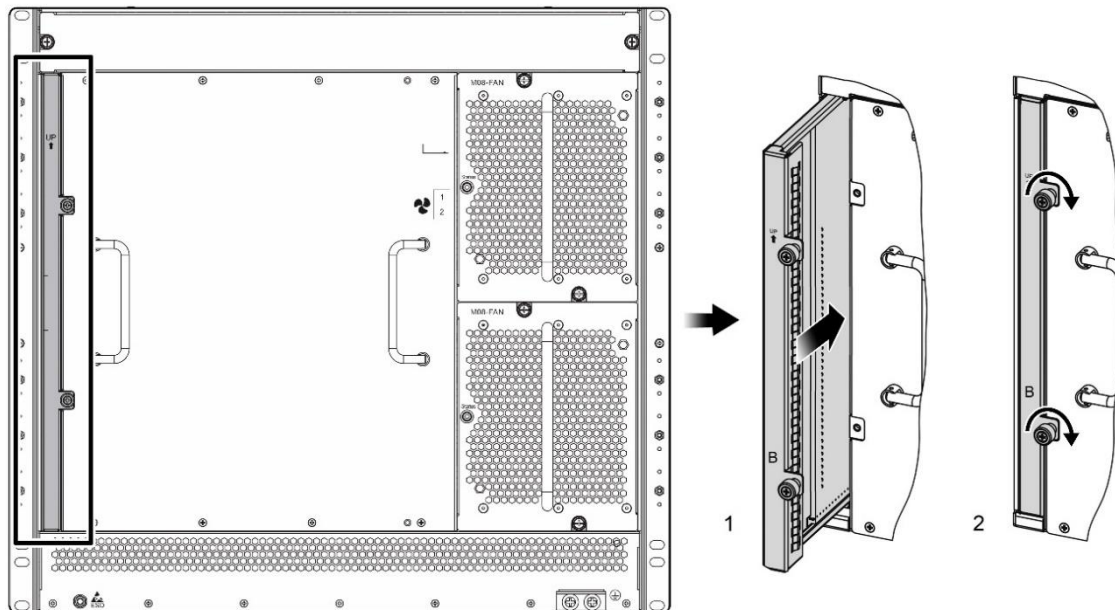

3.4 Mounting Cable Management Brackets

Note

- Make sure the antistatic wrist strap is grounded well and wear the antistatic wrist strap.
- The RG-CS88-08 cable management bracket is not mounted before delivery. See the following steps and figures for installation.

- Mount the cable management bracket for RG-CS88-08

- (1) Take out cable management brackets.
- (2) There three cable management brackets on each side respectively. Pay attention to the direction to mount cable management brackets, as shown in [Figure 3-3](#).
- (3) Align the screw holes on the cable management bracket with those on the chassis and tighten the screws, as shown in [Figure 3-3](#).

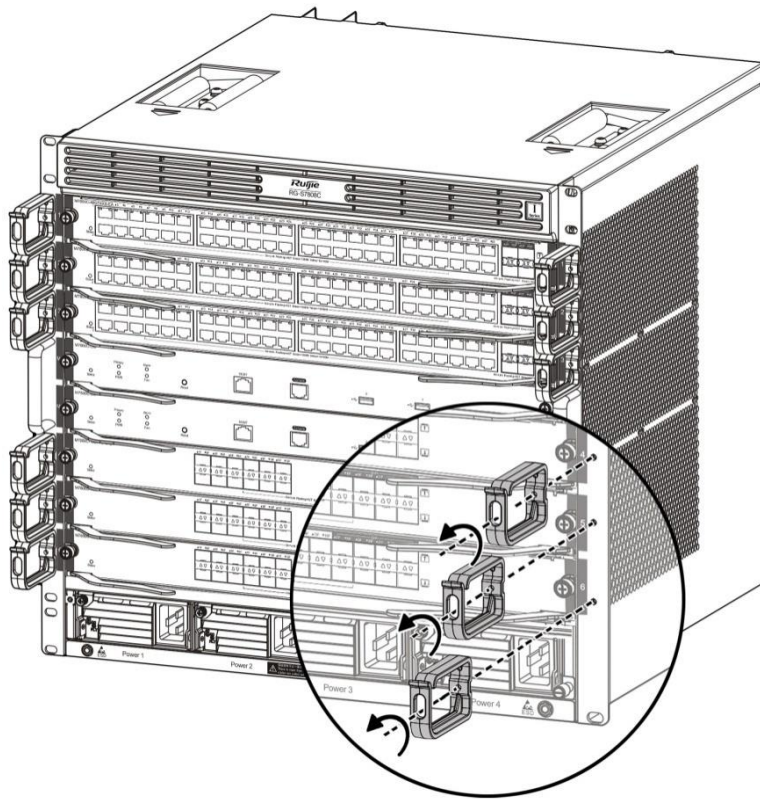
Figure 3-3 Mounting the Cable Management Bracket for RG-CS88-08

3.5 Mounting the Cabinet

Precautions

When you install the cabinet, pay attention to the following:

- All expansion bolts for fastening the cabinet base to the ground should be installed and tightened in sequence from bottom up (large plain washer, spring washer, and nut), and the installation holes on the base and the expansion bolts should be well aligned.
- After the cabinet is installed, it should be stable and still.
- After the cabinet is installed, it should be vertical to the ground.
- When multiple cabinets are put side by side in the room, they should be aligned in a straight line, with an error less than 5 mm.
- The front/back doors of the cabinet should be properly installed. You can open and close them smoothly. The locks should work normally, and all keys should be complete.
- There should be no unnecessary formal labels inside the cabinet and on various boards.
- Blank panels should be installed completely.
- Fastening screws of various devices in the cabinet of the same model should be ready and tightened.
- Various boards of the equipment should be installed securely, and the fastening screws on the panel should be tightened.
- All wiring inlets at the top and bottom of the cabinet should be installed with rodent-resistant nets where the

seams should be no more than 1.5 cm in diameter, to prevent rodents and other small animals from entering the cabinet.

- Antistatic wrist straps should be provided in the cabinet.

Installation Steps

- (1) Reserve sufficient space for front and back doors of the cabinet for maintenance.
- (2) Mount the cabinet at the designed location as planned.
- (3) Install the appropriate cable management bracket and cables.
- (4) Install the tray and wiring layer on the rack according to the configuration of one rack with one cabinet installed or one rack with multiple cabinets installed.

Installing Slide Rails

Before installing a slide rail, you need to have some knowledge of standard 19-inch cabinets of IEC60297. The height of standard cabinets is measured in Rack Unit (RU, 1 RU = 44.45 mm (1.75 inch)). 1 RU is equal to the height of three holes (see [Figure 3-4](#)). The hole in the middle is an auxiliary installation hole, and the other holes are standard installation holes. Note that the space between neighboring standard installation holes is a little smaller than that between an auxiliary installation hole and its neighboring standard installation hole. When installing a slide rail for the RG-CS88-08 series, ensure that the plane to carry the chassis should be installed on the plane of delimiters (entire-U delimiter) of the two neighboring RUs as shown in [Figure 3-4](#).

Figure 3-4 Slide Rail

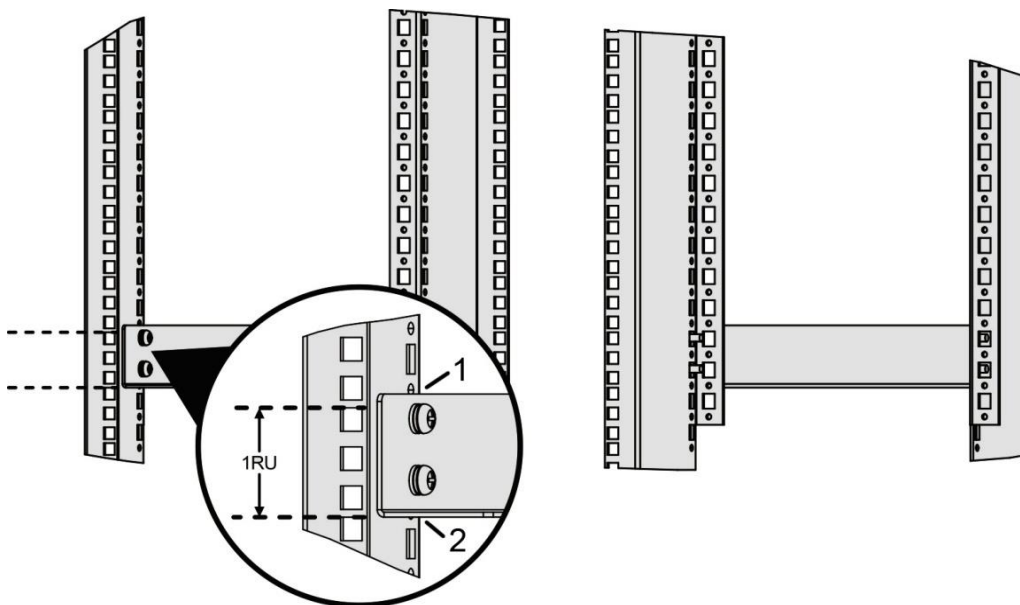

Note:	① and ② representing entire-U delimiters
-------	--

⚠ Caution

- Before installing a slide rail, make sure that the weight capacity of the slide rail meets requirements.
- There are variable kinds of slide rails. The rail appearance and installation is subject to actual conditions.
- In order to keep the cabinet balanced, please install the slide rail to as low a position as possible in the cabinet if only one RG-CS88-08 switch is installed. If you are mounting multiple devices to the cabinet,

mount the heaviest device in the lowest position of the cabinet first and proceed to mount the rest of the devices from bottom to top.

- It is recommended to install the power socket after planning on available space properly. Otherwise, there may be problems for operation.
-

3.6 Mounting the Switch to a Cabinet

Precautions

Before mounting RG-CS88-08 into the cabinet, first verify that the front and back brackets of the cabinet are at the right locations. If the bracket is too far forward, the front panel of the equipment may be too close to the front door, so that the front door cannot be closed when network cables and pigtail fibers are connected. Usually, you should reserve at least 10mm between the front panel of the equipment and that of the cabinet after installation. Before mounting into a cabinet, you need to address the following conditions:

- Fasten the cabinet.
 - The modules in the cabinet are installed.
 - There are no obstructions in and around the cabinet.
 - Prepare the equipment and move it to the place near the cabinet where you can handle it easily.
-

Note

Three people are recommended to carry or lift the switch. One is responsible for directing and the other two carrying or lifting the switch.

Installation Steps

Measure the cabinet height and locate the position on the bracket for installing the slide rail. Then locate the position on the other bracket through the carrying plane and mark the locations. Install seven cage nuts on the marked square holes on each bracket as shown in [Figure 3-5](#).

Figure 3-5 Slide Rail Installation Positions

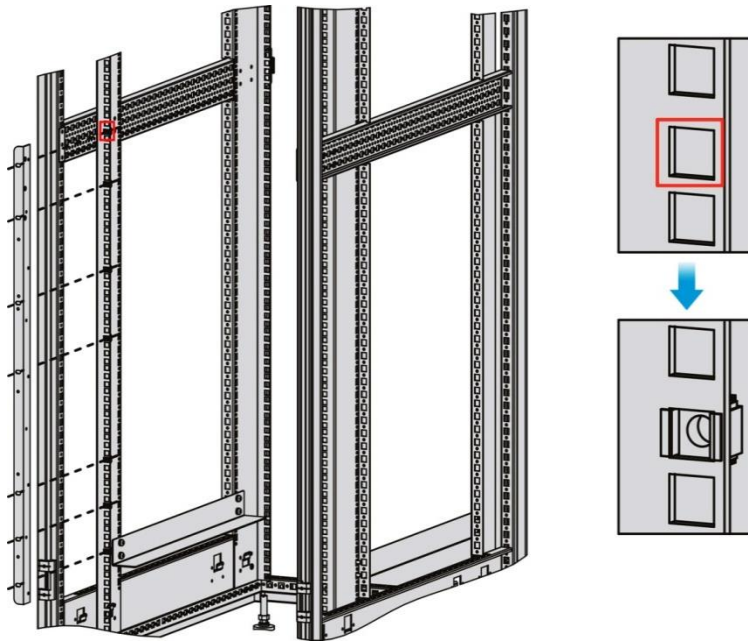

Place the switch on the slide rail, and drive it smoothly into the cabinet until the front bracket reaches the square hole strip.

Align the installation holes on the bracket with the cage nuts on the square hole strip, and mount them with screws.

Figure 3-6 Mounting the Switch into the Cabinet

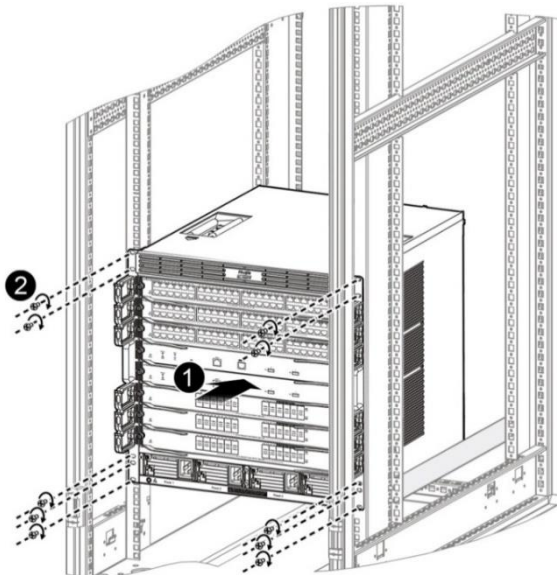

3.7 Connecting the System Ground

Note

A good grounding system protects your switch against lightning strikes and interferences and ensures its normal operation and reliability.

Precaution

- The sectional area of the grounding wire should be determined according to the possible maximum current. Cables of good conductor should be used.
- Do not use bare wire.
- The grounding resistance for combined grounding should be less than 1Ω .

Connecting the System Ground

To connect the system ground, follow these steps:

- (1) Remove the two screws on the rear of the switch.
- (2) Attach the one end of the grounding wire to the switch with the two screws. Connect the other end of the grounding wire to the grounding wire of the cabinet.

Figure 3-7 Grounding Lug on the Rear of the RG-CS88-08 Switch

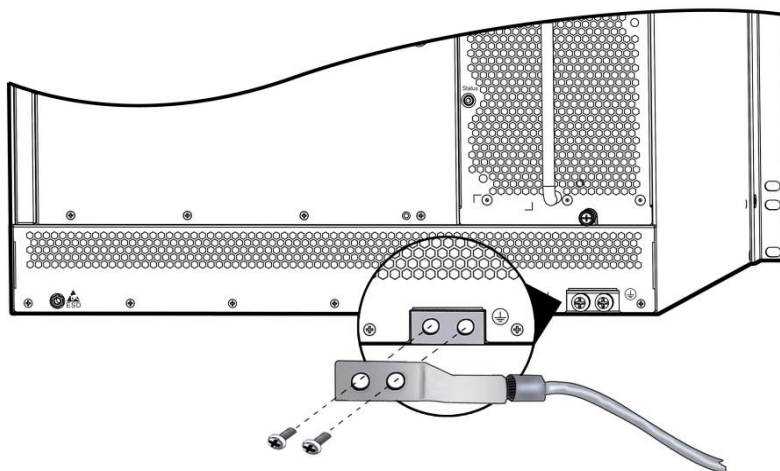

Caution

- To guarantee the security of the person and the device, the RG-CS88-08 must be well-grounded. The grounding resistance shall be less than 1Ω .
- A service person shall check whether or not the socket-outlet from which the equipment is to be powered provides a connection the building protective earth. If not, the service person shall arrange for the installation of a protective earthing conductor from the separate protective earthing terminal to the protective earth wire in the building.
- The socket-outlet shall be installed near the equipment and shall be easily.
- When installing the unit, always make the ground connection first and disconnect it last.
- The cross-sectional area of protective earthing conductor shall be at least 2.5 mm^2 (12AWG).

3.8 Installing Power Supplies

The RG-CS88-08 series switches provide two system power supplies: RG-PA1600I-F and RG-PA600I-F AC power supplies. Before performing the following procedures, wear an anti-static wrist strap close to your kin and keep it grounded well.

Note

- The RG-CS88-08 power system provides four power supply slots, which support 1+1 redundancy.
- When RG-CS88-08 is powered up by more than one source, the power must be in the same model.
- If you want to carry or lift the power module, please hold the bottom of the module with your hand instead of carrying the module by the handle. Otherwise, the module may be damaged.
- Before inserting or removing the power module, please verify whether the switch is well mounted. The switch is high, avoid switch tumble when you are inserting or removing the power module.
- If you want to hot swap a power supply, please make sure that the interval between two operation is greater than 30 seconds.
- Please do not touch the connecting finger part of the power supply which is removed after power off in case that capacitor discharge is not full.

- Install the AC power module on RG-CS88-08
 - (1) Loosen the captive screws on the filler panel covering the power slot at the rear of the chassis.
 - (2) Insert the power module into the slot along the rail until the rear connector of the power module stays in good contact with the rear panel.
 - (3) Tighten the captive screws on the power module to fix it.

Figure 3-8 Installing Power Supplies

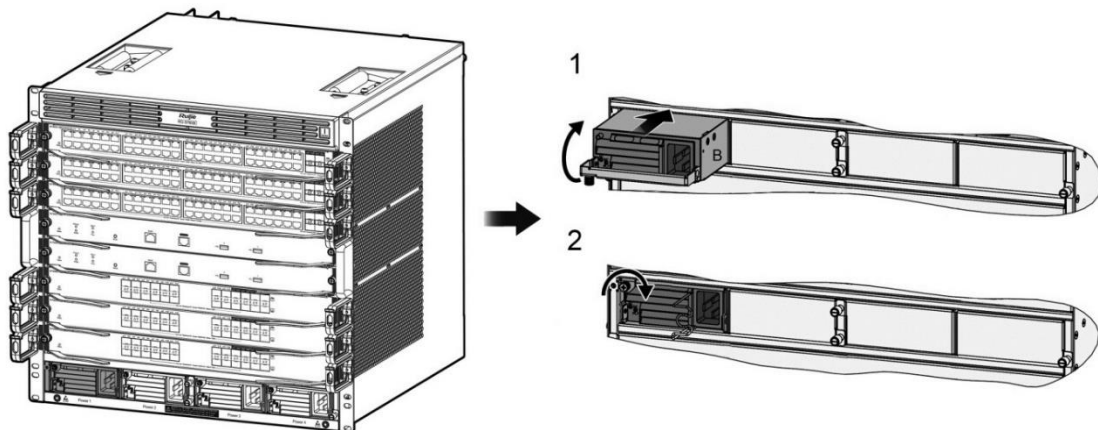

Caution

The total power of power supplies of the RG-CS88-08 must be greater than the working power of the host. Otherwise, some modules may fail to start.

Note

The host power is the summation of the power of all working modules, including the supervisor module, service module and fan. For the power consumption of each module, see the module specifications.

3.9 Installing Fans

RG-CS88-08 adopt M08-FAN module for heat dissipation respectively. Before the following procedures, wear an anti-static wrist strap close to your skin and have it properly grounded.

- Steps for installing the M08-FAN fan tray:

- (1) Install the fan tray into the fan slot in the rear panel of RG-CS88-08. Note the direction identifier of the fan tray's name to ensure the correct direction.
- (2) Tighten the captive screws on the fan tray with a screwdriver.

Figure 3-9 Installing M08-FAN Fan Tray

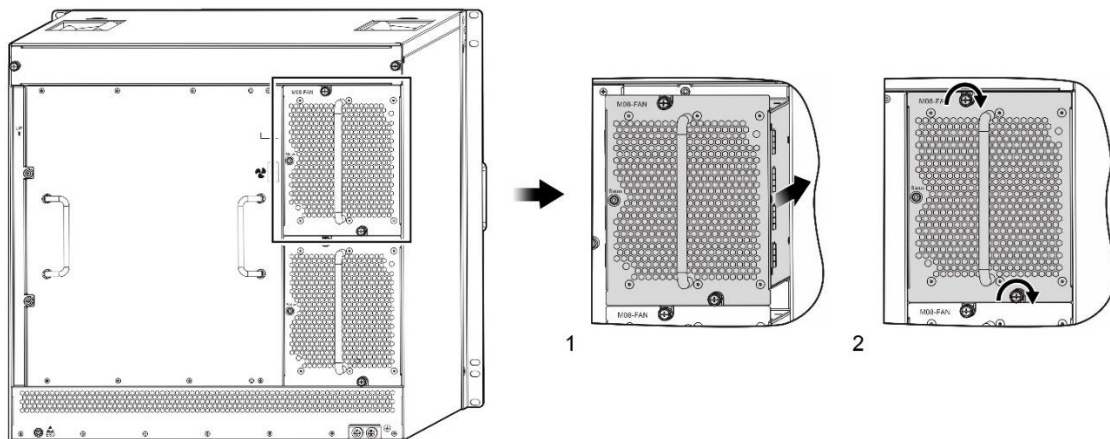

Caution

Do not remove the fan tray forcibly. You can use the fan handle. Otherwise, component damage may occur, which causes deformation of the fan tray, and the fan tray cannot be removed.

3.10 Installing Modules

Always wear an anti-static wrist strap when installing the module and the metallic part of the anti-static wrist strap should be fully touched with the skin. Besides, for the sake of security, please not touch any component of the module.

Caution

- Do not hold the edge of the PCB or collide the components on the PCB.
- Do not plug/unplug a supervisor module, service module or switch fabric module forcedly, use the ejector.

- Select Slots

Note

For the slot location of the supervisor module and service module.

Figure 3-10 RG-CS88-08 Chassis

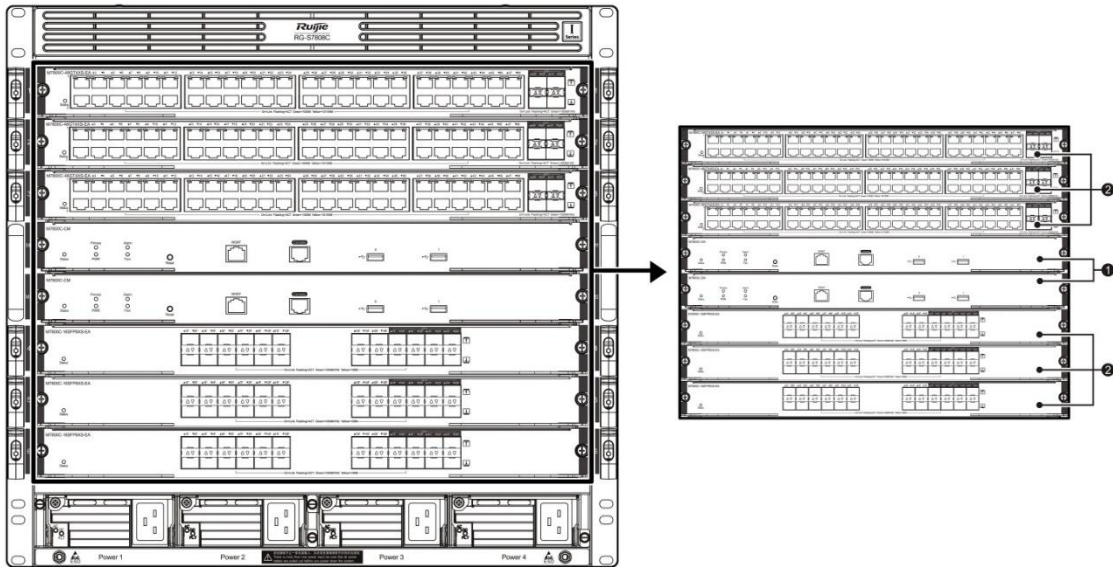

Note:	① Supervisor module slot	② Service module slot
-------	--------------------------	-----------------------

- Install modules

Note

See the following figure for installing the supervisor module and the service module.

- Steps for installing the RG-CS88-08 module:

- (1) Pull out both levers (① in [Figure 3-11](#)).
- (2) Insert the module into the slot along the slide rail and drive it ahead smoothly (② in [Figure 3-11](#)).
- (3) Push both levers toward the slot (③ in [Figure 3-11](#)).
- (4) Tighten the captive screws on the fan tray with a screwdriver (④ [Figure 3-11](#)).

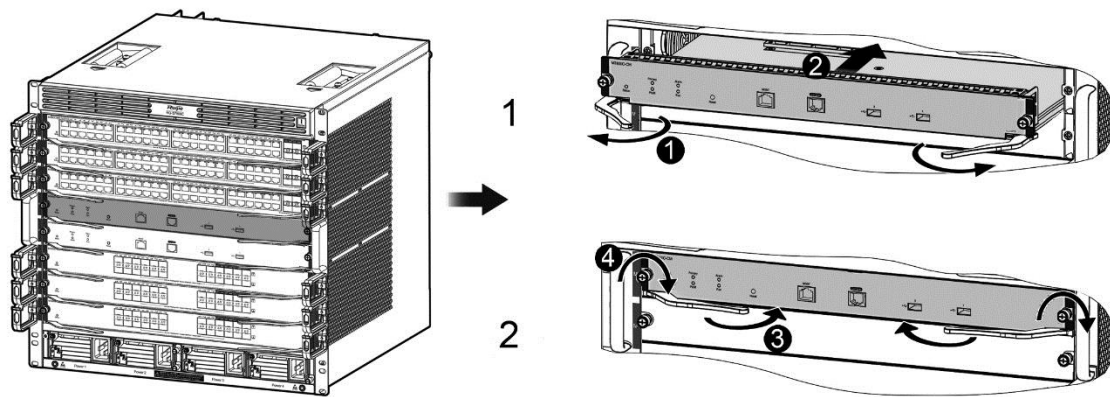
Figure 3-11 Installing the RG-CS88-08 module**⚠ Caution**

If any module slot is unoccupied, install a filler panel to ensure proper airflow.

3.11 Installing Swappable Interface Modules (Optional)**⚠ Caution**

Make sure the optical modules connected to both ends of a fiber are the same type while replacing swappable optical modules.

Preparation

- (1) Wear an anti-static wrist strap to your wrist and tighten the lock. Make sure it is properly grounded.
- (2) Take out the SFP+/SFP/QSFP+ module you want to install from packing bag. Do not touch the connecting finger on the module.

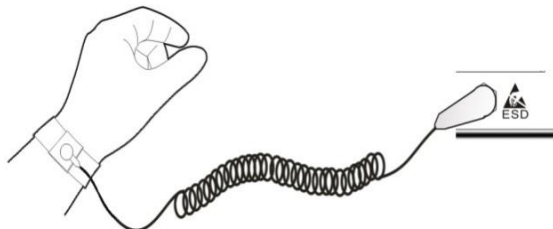
Figure 3-12 Wearing an Anti-Static Wrist Strap

3.11.2 Installing SFP+/SFP Modules

⚠ Caution

To avoid damaging components due to operation errors, read this section carefully before installing SFP+/SFP modules.

To install the SFP/SFP+ module, do as follows:

- (1) Turn up the handle of the module into the top bail-clasp latch. Hold both sides of the module and push the module into place (You can feel that the module is placed in position with a click sound).

Figure 3-13 Installing the SFP/SFP+ Module

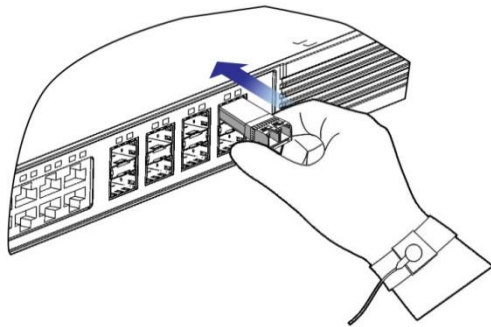

- (2) Use the fiber optical patch cord to connect the SFP/SFP+ module to the fiber optical network. Select the patch cord with the connector corresponding to the port.
- (3) After the patch cord is connected, the Link/ACT Status LED is on. Otherwise, please check connection of the patch cord.

Precaution

- If the SFP/SFP+ module cannot be inserted to the end, do not push it forcefully. Please try the other end of the module.
- Do not touch the connecting finger on the module.
- Do not squeeze, bend or fold the optical fiber, which may cause system performance degradation or data loss.
- Do not remove the protective rubber plug from SFP+/SFP module before connecting fibers.
- Do not insert the SFP+/SFP module with a fiber into a slot. Unplug the fiber before installing the module.

3.11.3 Installing SFP+ Cables

⚠ Caution

To avoid damaging components due to operation errors, read this section carefully before installing SFP+ cables.

- (1) To install the SFP+ copper module, do as follows: You can install the SFP+ copper module with power on. Hold the connector of a copper cable module with one hand and carry the cable to the front panel of the

switch with the other. Push the module gently into the SFP+ module slot until you hear a click, indicating the module is correctly installed.

Figure 3-14 Installing SFP+ Copper Module

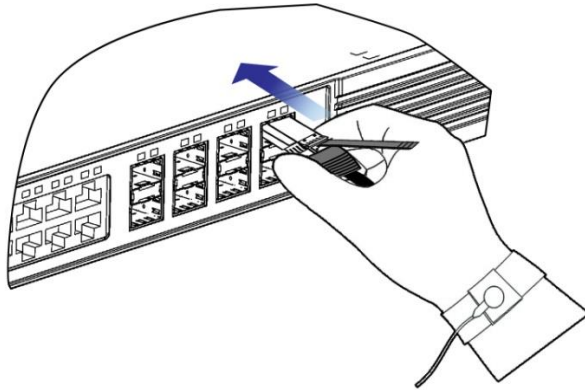

(2) After you connect the copper module to the Ethernet network through the connector, the Link/ACT status is on. Otherwise, please check the connector.

Precaution

- If the SFP+ copper module cannot be inserted to the end, do not push it forcefully. Please try the other end of the module.
- Do not touch the connecting finger on the module.
- Do not squeeze, bend or fold the copper cable, which may cause system performance degradation or data loss.

Caution

After the cable is plugged, make sure that the bending radius is greater than 5 times of the cable diameter. Too small bending radius may cause damage to the copper cable. For example, if the cable diameter is 4.9mm, the bending radius should be 24.5mm at least.

Figure 3-15 Bending Radius and Cable Diameter

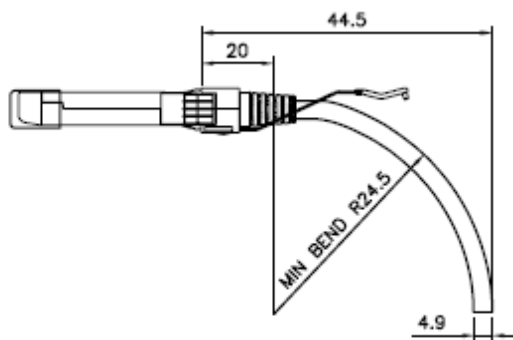

Use an SFP+ cable to connect two SFP+ ports close to each other. Take the following steps to install the SFP+ module:

- (1) Wear an anti-static wrist strap close to your skin and have it properly grounded.
- (2) Take out the SFP+ module you want to install from the packing bag.
- (3) Plug the SFP+ cable to the SFP+ port through the connector. Pay attention to the proper end for connection.

⚠ Caution

During the operation, make sure that the cable's bending radius is no less than eight times as much as its diameter.

3.11.4 Installing 40-Gigabit QSFP+ Modules

⚠ Caution

To avoid damaging components due to operation errors, read this section carefully before installing 40-Gigabit QSFP+ modules.

Take the following steps to install 40-Gigabit QSFP+ modules:

- (1) Turn up the handle of the module into the top bail-clasp latch. Hold both sides of the module and push the module into place (You can feel that the module is placed in position with a click sound).
- (2) Push the module gently into the QSFP+ module slot until you hear a click, indicating the module is correctly installed .

Figure 3-16 Installing the QSFP+ Module Equipped with a Bail-Clasp Latch

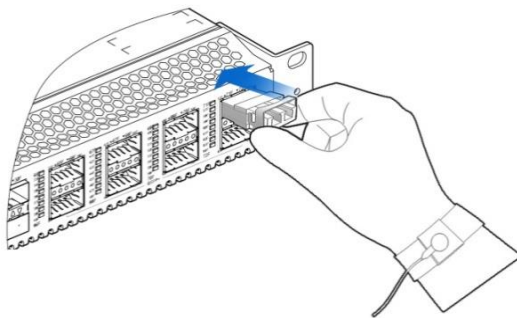
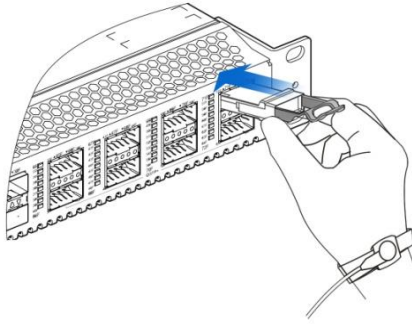

Figure 3-17 Installing the QSFP+ Module Equipped with a Pull Tap

- (3) Use the fiber optical patch cord to connect the 40G QSFP+ module to the fiber optical network. Select the patch cord with the connector corresponding to the port.
- (4) After the patch cord is connected, the Link/ACT Status LED is on. Otherwise, please check connection of the patch cord.

Precaution

- Pay attention to the proper end of the QSFP+ module for installation. If the QSFP+ module cannot be inserted to the end, do not push it forcefully. Please try the other end of the module.
- It is recommended that you do not remove the protective rubber plug from QSFP+ module before connecting fibers.
- It is recommended that you do not insert the QSFP+ module with a fiber into the slot. Unplug the fiber before installing the module.
- Do not touch the connecting finger on the module.
- Do not squeeze, bend or fold the optical fiber, which may cause system performance degradation or data loss.

3.11.5 Installing 40-Gigabit QSFP+ Cables

⚠ Caution

To avoid damaging components due to operation errors, read this section carefully before installing 40-Gigabit QSFP+ copper cables.

Take the following steps to install 40-Gigabit QSFP+ copper modules:

- (1) You can install the QSFP+ copper module with power on. Hold the connector of a copper cable module with one hand and carry the cable to the front panel of the switch with the other. Push the module gently into the QSFP+ module slot until you hear a click, indicating the module is correctly installed.

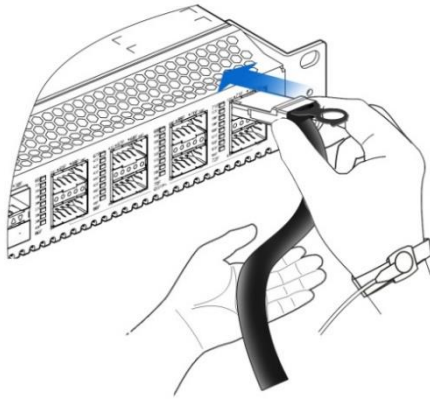
Figure 3-18 Installing the QSFP+ Copper Module

(2) After the cable is connected, the Link/ACT Status LED is on. Otherwise, please check the connector.

Precaution

- If the QSFP+ copper module cannot be inserted to hit the back panel, do not push it forcefully. Please try the other end of the module.
- Do not touch the connecting finger on the module.
- Do not squeeze, bend or fold the copper cable, which may cause system performance degradation or data loss.

⚠ Caution

After the cable is plugged, make sure that the bending radius is greater than 5 times of the cable diameter. Too small bending radius may cause damage to the copper cable. For example, if the cable diameter is 7.4mm, the bending radius should be 35mm at least, as shown in [Figure 3-19](#):

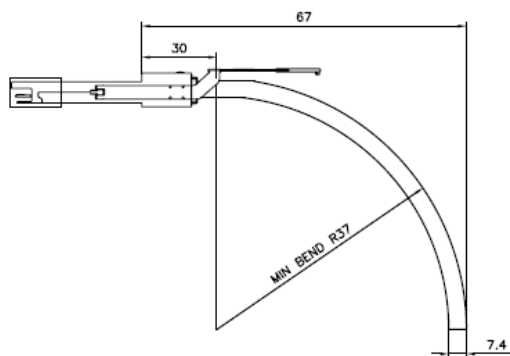
Figure 3-19 Bending Radius and Cable Diameter

3.12 Connecting the Power Cord

3.12.1 Connecting the AC Power Cord

Connect the power cord to the location as required according to the identification on the AC power module panel, including RG-PA1600I-F and RG-PA600I-F.

Note

Make sure the socket is powered off before the power cord is connected.

- Connect the AC power cord
 - (1) Insert the AC power plug into the power module socket.
 - (2) Take out the retention clip.
 - (3) Install the retention clip on the front panel of the power module
 - (4) Pull down the retention clip over the plug on the power cable.
 - (5) Connect the other end of the power cord to an external power socket.

Figure 3-20 Connecting the Power Cord on RG-CS88-08

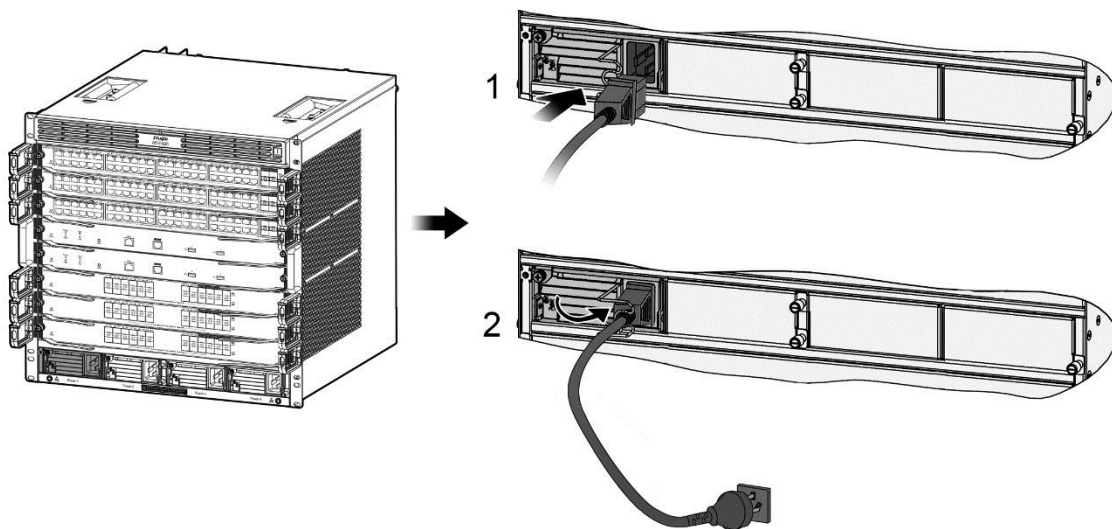

Caution

- Please use the 3-pin power cord. The cross-sectional area of each pin is 1.5 mm² or 14 AWG minimum.
 - 16A and 10A power cords are available for the RG-CS88-08 AC power supply. Adopt the proper socket and verify the AC power supply capacity in the machine room.
-

3.13 Installation Verification

- Verify if the external power supply matches the distribution panel of the cabinet.
- After installing the equipment, verify if the front/back cabinet doors can be closed.

- Verify that the cabinet has been fastened completely, and does not move or tilt.
- Verify that the equipment has been installed in the cabinet, and all the cables have been fastened to the cabinet.
- Verify that the fan meets the requirement.
- Verify that the power supply is properly selected.
- Verify that the power module is inserted properly and the screws are fastened tightly.
- Please do not power up the switch by yourself and do not perform live-line maintenance.
- Verify that there is no potential danger in the working area, for example, the power supply is not grounded well, or the ground is wet.
- Please do not place the switch at a damp place to prevent the moisture from entering the switch.
- Be sure of the location of the emergency power switch. If an emergency occurs, cut off the power first.
- Verify that all power supplies are turned off if you want to turn off the power.
- Verify that the power cord is connected properly.
- Verify that the power cord is long enough to avoid being stretched.
- Verify that the rated current of the external power socket is greater 16A and that the socket is grounded well.
- Verify that each power module is connected to a power socket.
- Verify that the vacant slot is covered with a filler panel for ventilation and heat dissipation.

4 System Debugging

4.1 Establishing the Configuration Environment

Establishing the Configuration Environment

Note

If you log in to the switch for the first time, please use the Console port.

Connecting the Console Cable

- (1) Connect one end of the DB-9 jack of the console cable to the serial port of the PC.
- (2) Connect one end of the console cable RJ45 to the Console port of the switch.

Figure 4-1 Connecting Switch and PC through Console Port

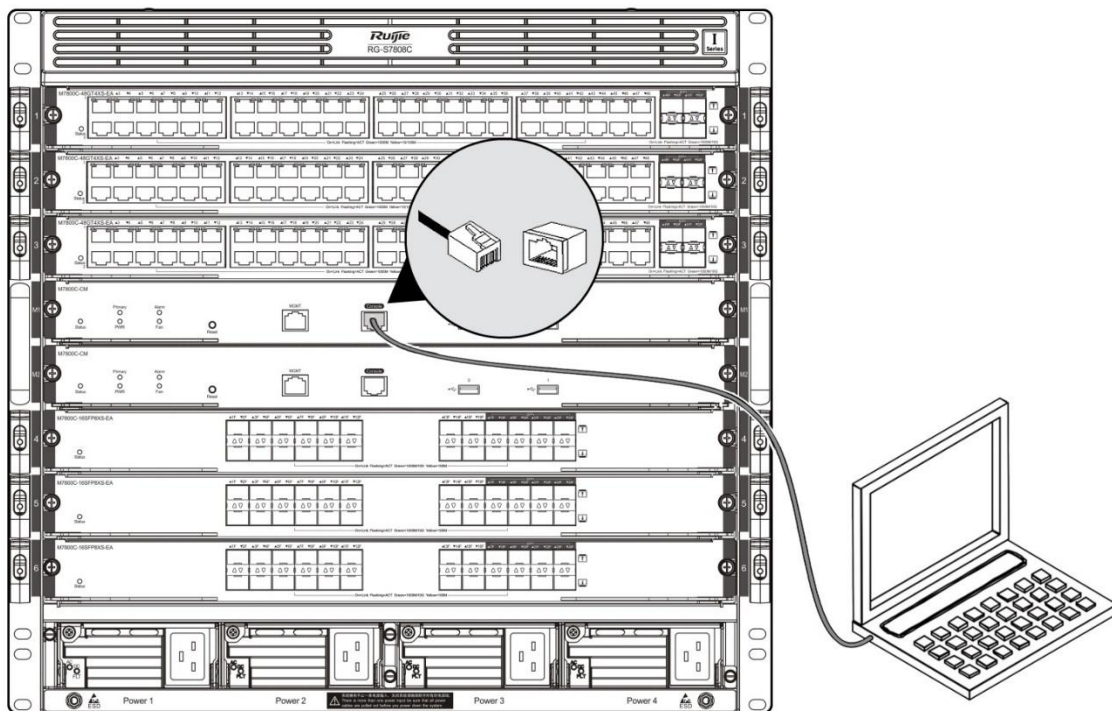

Setting Terminal Parameters

- Start the PC and run the terminal simulation program on the PC, such as Terminal on Windows 3.1 or HyperTerminal on Windows 95/98/NT/2000/XP.
- Set terminal parameters. The parameters are as follows: baud rate 9600, data bit 8, parity check none, stop bit 1, and flow control as none. Details are as follows:
 - (1) Choose **Start > Programs > Accessories > Communications > Hyperterminal**. The hyperterminal window appears.

- (2) Click **Cancel**. A window appears as shown in [Figure 4-2](#).

Figure 4-2



- (3) In the **Connectivity Note** window, type the name of the new connection and click **OK**. A window appears as shown in [Figure 4-3](#). In the **Connect Using** field, select the serial port you want to use.

Figure 4-3

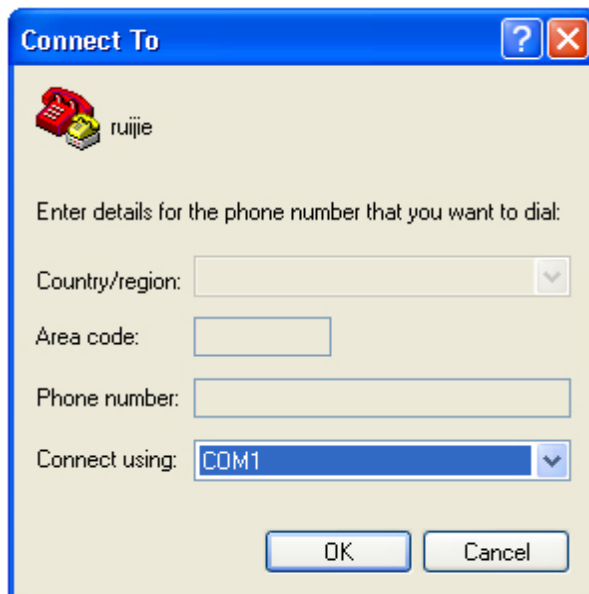

- (4) After selecting the serial port, click **OK**. The **Serial Port Parameter Setting** window is displayed, as shown in [Figure 4-4](#). Set the baud rate to 9600, data bit to 8, parity check to none, stop bit to 1, and flow control to none.

Figure 4-4

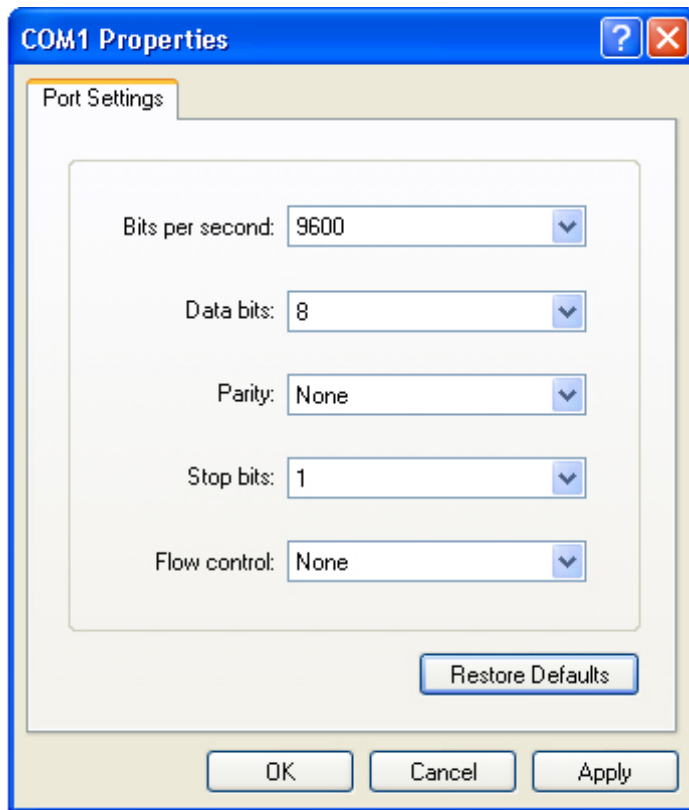

(5) After setting the serial port parameters, click **OK**. The Hyperterminal window appears.

4.2 Power-on Startup

Checking Before Power-on

- The switch is fully grounded.
- The power cable is correctly connected.
- The power supply voltage complies with the requirement of the switch.
- The console cable is correctly connected; the terminal (can be a PC) used for configuration is already started; the parameters are already configured.

Checking After Power-on (Recommended)

After power-on, you are recommended to perform the following checks to ensure the normal operation of follow-up configurations.

- Check that information appears on the terminal interface.
- Check that the device indicator is normal.

5 Monitoring and Maintenance

5.1 RG-CS88-08 Monitoring

Indicators

When the RG-CS88-08 is running, you can monitor the status of each module by inspecting the status LED of the appropriate module.

- When the Alarm LED of the master supervisor module is red, it means the system has a fault, in which case you can log in to the management software to perform troubleshooting.
- When the Alarm LED of the master supervisor module is yellow, it means the system temperature exceeds the alarm temperature, affecting the system operation performance. However, the system can continue running. In this case, you can log in to the management software to perform troubleshooting.
- When the Status LED of the fan tray is red, it means that the fan tray is not power-on or the fan tray is faulty, you can log in to the management software to perform troubleshooting.
- When the Status LED of a module is OFF, RED, or blinking, it means that the module is faulty, in which case you need to find out the cause, and turn off the power when necessary.

CLI Commands

The RG-CS88-08 allows you to monitor various system statuses by executing the appropriate CLI commands, including:

- Module in-position status
- Port configuration information and status
- Fan and power supply working status
- Temperature status

Note

- For the monitoring commands, see RG-CS88-08 series Software Configuration Guide.
 - RG-CS88-08 supports remote maintenance. If RG-CS88-08 and the Internet are connected, the user can log in to the RG-CS88-08 via Telnet and maintain RG-CS88-08 remotely through various monitoring commands.
-

5.2 Hardware Maintenance

Module Maintenance

To replace a module, do replacement according to the instructions provided in Sections of Installing Modules and Removing Modules.

Cooling System Maintenance

- The fan in the equipment is provided with the fault monitoring signals. When the fan fails, an appropriate alarm will occur.
- To replace the fan, first loosen the captive screw on the fan tray.

- Replace the failed fan with a good one.
- Tighten the captive screws of the fan tray.

⚠ Caution

- Complete fan replacement within 30 seconds when the device is electrified.
 - The air filter for the RG-CS88-08 shall be cleaned periodically (generally once every three months) by dry cleaning or washing. Do not rub during the cleaning or washing and flat dry after the cleaning or washing.
-

Power Supply Maintenance

When the power supply fails, you only need to disconnect the power cable, loosen the two panel screws on the power module, unplug the power module, replace it with a good one, and tighten the panel screws, and then connect the power cables.

Replacing Fuses

To replace the old fuse wire with the correspondent new one, please contact the technical support representatives of Ruijie Networks. The following table lists the specifications for the module fuses.

Module	Fuse Slot Number	Fuse Specification
M08-FAN	F1	F 15A/65V
CM88-CM	F1	F 10A/125V
CM88-48SFP-H	F1	F 30A/125V
CM88-48GT-H	F1	F 30A/125V
CM88-8CQ-H	F1	F 40A/60V
CM88-48XS-H	F1	F 40A/60V

6 Troubleshooting

6.1 General Installation Troubleshooting Flow

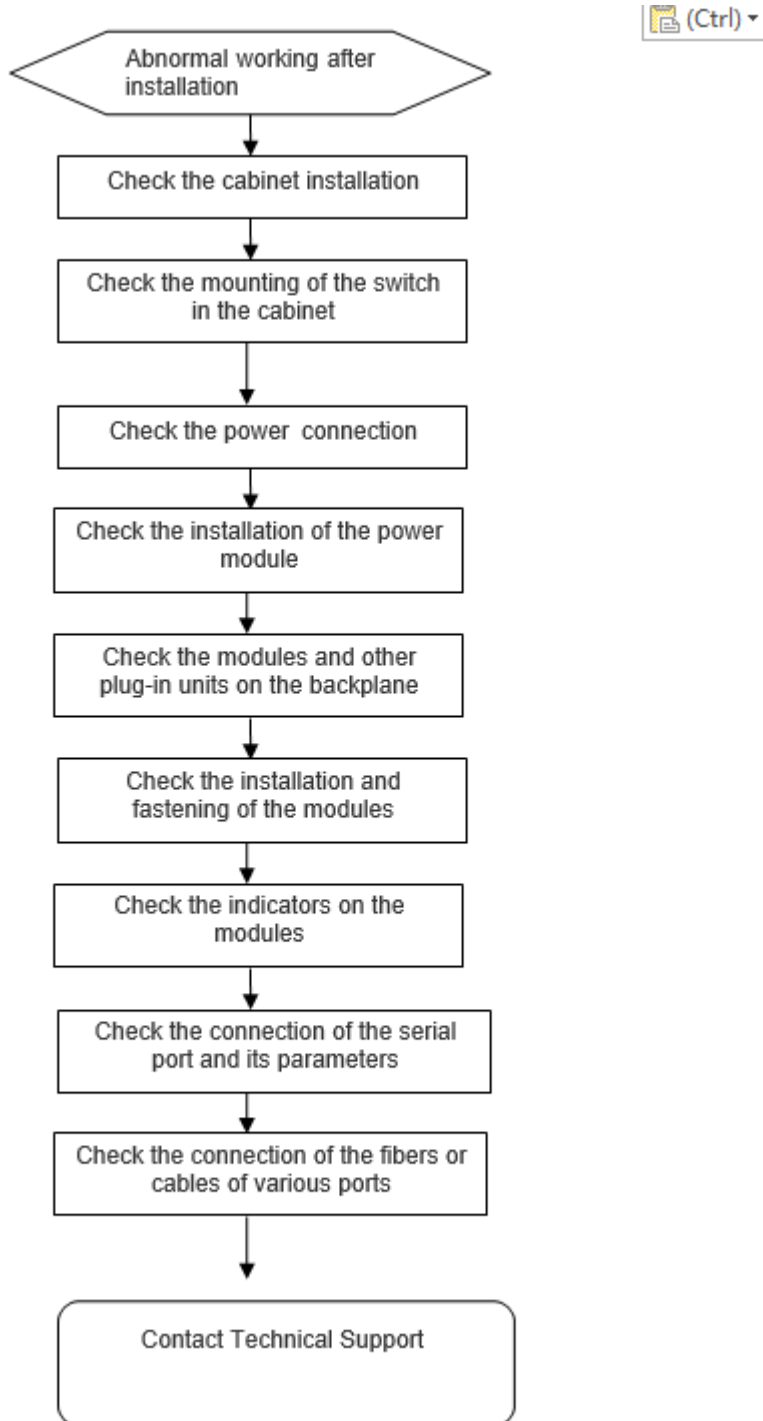

6.2 Common Troubleshooting Procedures

Fault 1: The AC power module does not work.

- Fault Description:
 - The Status LED of each service module is OFF, the Power LED of the fan tray is OFF, and the fan does not work.
 - The LED on the panel of the power module is OFF. The fan does not work.
- Troubleshooting:

First place the switches of all the power modules to OFF. Check if the cables of the cabinet have been correctly connected. Check whether the power cables are tightly connected to the cabinet power sockets and power modules. Check whether the power modules are installed correctly. If necessary, pull out the power modules and check whether the connectors on the backboard of the power system are tightened.

Fault 2: An exception occurs to the LEDs when service modules are powered on.

- Fault Description:

The Status LED of the service module is OFF, blinking, or RED. The Link/ACT LED of the service module is solid ON when no network cable or fiber is plugged.
- Troubleshooting:

Check if the service module is firmly inserted. If so, install the service module again and ensure that it is inserted into place before you tighten the fastening screws. If the service module still does not work, check if the connector of the slot on the backplane is loose. If yes, insert the service module to another slot for a try. If the slot and connection are not the cause, return the service module for repair.

Fault 3: The LED is abnormal after a service module works for some time.

- Fault Description:

The Status LED of the service module is OFF or RED. The Link/ACT LED of the service module is solid ON when no network cable or fiber is plugged. The fault remains after restart.
- Troubleshooting:

Check if the service module gets loose. If so, install the service module again and ensure that it is inserted into place before you tighten the fastening screws. If the module still does not work, check if the connector of the slot on the backplane is loose and check if the slide rail of the slot is deformed. If so, insert the service module to another slot for a try. If the slot and connection are not the cause, return the service module for repair.

Fault 4: The LED of the supervisor module is abnormal.

- Fault Description:

The LED of the supervisor module becomes abnormal after the supervisor module is powered on or works for some time. For example, the Status LED is blinking or OFF, and the Alarm LED is red.
- Troubleshooting:
 - Check if the supervisor module gets loose. If so, install the supervisor module again and ensure that it is inserted into place, before you tighten the fastening screws. If the supervisor module still does not work, check if the connector of the slot on the backplane is loose and check if the slide rail of the slot is deformed. If yes, insert the module to another slot for a try. If the slot and connection are not the cause,

return the supervisor module for repair.

- When the Alarm LED is red, the cause may be the fault of another module in the system, in which case you can check other modules (for example, service module, fan, power, and overheating) for any alarm. If yes, you should first handle the faults of other modules. You can also identify the faults by logging in to the management software.

Fault 5: The fan tray does not work or the LED is abnormal.

- Fault Description:

After the system starts, the fans in the fan tray do not work or the status LED is OFF.

- Troubleshooting:

Check if the connection between the fan tray and the backplane is secure and if the connector gets loose. If the connection is secure, you need to replace the fan tray.

Fault 6: The serial port console has no output.

- Fault Description:

After the system is started, the serial port console does not display any information.

- Troubleshooting:

Check whether serial port cables are connected correctly and whether the connected serial port is identical with that configured on the super terminal. Check whether the configuration of the serial port on the super terminal is the same as that described in *RG-CS88-08 Software Configuration Guide*. If not, modify the serial port configuration parameters. If there is still no serial port printed information, please contact Ruijie Customer Service Department for technical support.

Fault 7: The serial port console outputs illegible characters.

- Fault Description:

The serial port console outputs illegible characters.

- Troubleshooting:

Such problem is related to the settings of the serial port. Check if the settings of such parameters as the baud rate match those in *RG-CS88-08 series Software Configuration Guide*.

Fault 8: The newly-inserted service module fails to be powered on.

- Fault Description:

The system is running, yet all LEDs on the panel of the newly-inserted service modules are OFF, and the port is faulty.

- Troubleshooting:

Check whether the service module is connected correctly and whether the summary power of the newly-inserted service module and other modules in the system exceeds the maximum power. If so, please add more power modules to provide the enough power for the power supply. If all checkings are OK, but the newly-inserted service module still cannot be powered on, please contact Ruijie Customer Service Department for technical support.

Fault 9: The link cannot be set up between fiber interfaces

- Fault Description:

The system runs normally. After the fiber interface is inserted into the optical module and the optical fiber is properly connected, the link cannot be set up.

- Troubleshooting:

First confirm whether the interface is a copper/fiber combo interface. If yes, it should be configured in fiber mode. Then, do as follows:

- a Check whether the receiving and sending ends are wrongly connected. The sending end of the fiber interface needs to be connected to the receiving end of the other fiber interface. You can check by changing the sequence in which the two optical fibers are connected on the optical module.
- b Check whether the optical module wavelength of the two sides are consistent. For example, an optical module of 1310nm wavelength cannot be connected to an optical module of 1550nm wavelength.
- c Check whether the distance between the two sides exceeds the length indicated on the optical module.
- d Check whether the rates of the two sides match and whether the optical fiber type meets requirements. In addition, for ports supporting different rates, check whether rate modes are configured correctly.

 **Note**

If above mentioned methods do not take effect, please contact Ruijie Networks technical support.

7 Replacing Modules

7.1 Removing, Cleaning and Installing Air Filter

Caution

After the air filter is used for a long time, the dust may block the holes on the air filter, affecting heat dissipation and ventilation. It is recommended that the air filter be cleaned every three months.

7.1.1 Removing, Cleaning and Installing Air Filters for Supervisor and Service Modules

- Install the air filter of RG-CS88-08 supervisor and service modules:
 - a Insert the air filter along the slide rail. Pay attention to the direction instruction on the air filter.
 - b Tighten the screws on the air filter with a screwdriver.
- Remove the air filter of RG-CS88-08 supervisor and service modules:
 - a Loosen the captive screws on the air filter.
 - b Remove the air filter.

Figure 7-1 Installing and Removing the Air Filter of RG-CS88-08 Supervisor and Service Modules

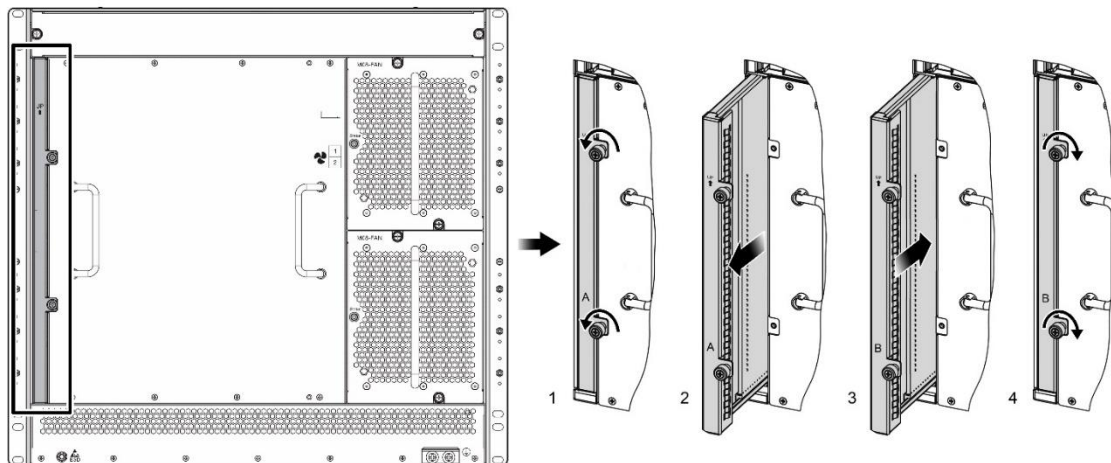

Note	A: Air filters to be removed	B: Air filters to be installed
------	------------------------------	--------------------------------

7.2 Removing Swappable Interface Modules (Optional)

7.2.1 Removing SFP+/SFP Modules

Take the following steps to remove SFP/SFP+ modules:

- (1) Unplug the optical fiber.

- (2) Turn down the handle of the module until it is horizontal. Pull the tab to take out the SFP/SFP+ module, as shown in [Figure 7-2](#).

Figure 7-2 Removing the SFP/SFP+ Module

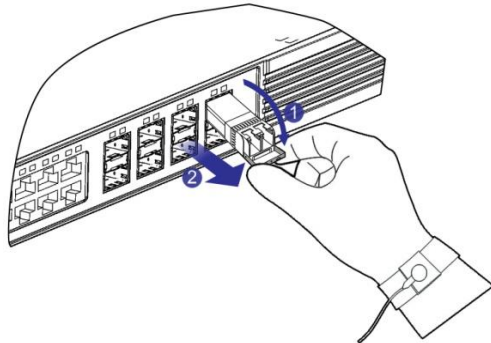

Precaution

- Unplug the optical fiber before removing the module.
- Do not pull out the module forcefully without turning down the handle of the module.
- Immediately install the dust plug to the module port and the switch fiber port.

7.2.2 Removing SFP+ Cables

Pull the tap out and unlock the module. Take out the SFP+ module gently, as shown in [Figure 7-3](#):

Figure 7-3 Removing the SFP+ Cable

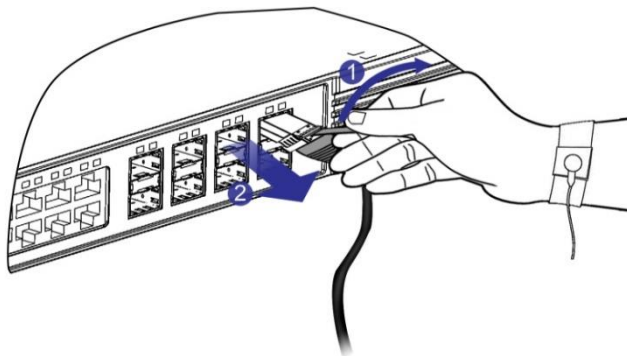

Precaution

- Pull the tab out before unplugging the cables. Otherwise, the module or the slot can be damaged.
- Immediately install the dust plug to the module port and the switch fiber port.

7.2.3 Removing 40-Gigabit QSFP+ Modules

- (1) Unplug the optical fiber.
- (2) If you want to remove the module equipped with a bail-clasp latch, turn down the handle of the module until it is horizontal and pull the bail-clasp latch to take out the QSFP+ module, as shown in [Figure 7-4](#). If you want

to remove the module equipped with a pull tap, pull the tap to take out the QSFP+ module gently, as shown in [Figure 7-5](#):

Figure 7-4 Removing the QSFP+ Module Equipped with a Bail-claps Latch

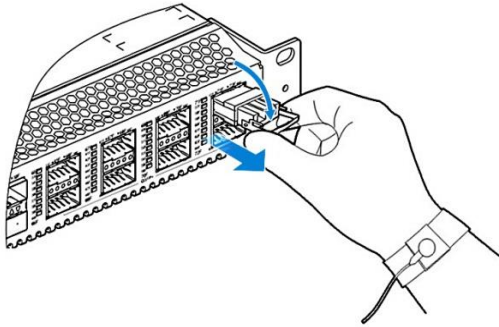
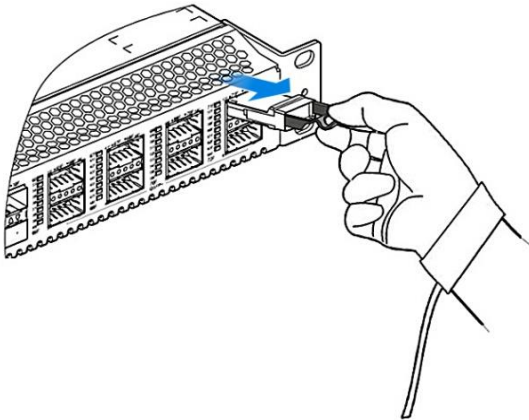

Figure 7-5 Removing the QSFP+ Module Equipped with a Pull Tap



Precaution

- Unplug the optical fiber before removing the module.
- Do not pull out the module forcefully without turning down the handle of the module.
- Immediately install the dust plug to the module port and the switch fiber port.

7.2.4 Removing 40-Gigabit QSFP+ Cables

Hold the cable with one hand and pull the tap to take out the module gently, as shown in [Figure 7-6](#):

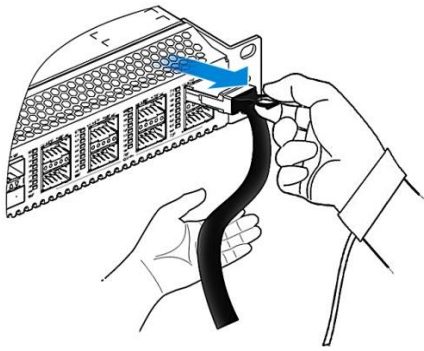
Figure 7-6 Removing the QSFP+ Cable**Precaution**

- Pull the tap out before unplugging the cables. Otherwise, the module or the slot can be damaged.
- Immediately install the dust plug to the module port and the switch fiber port.

7.3 Replacing Modules

Preparation

- (1) Wear an anti-static wrist strap close to your skin and have it properly grounded.
- (2) Take out the module from the package.

Take the following steps to replace the module:

- (1) Unplug all cables/fibers such as fibers and RJ45 twisted pairs from the panel.
- (2) Hold down self-locking lever buttons on both sides of the panel and pull out the lever.
- (3) Drag the lever to pull the module out, Before the module is about to be removed from the chassis, support the bottom of the module with one hand and hold the module with the other hand, so as to prevent the module from falling.
- (4) Pull out the levers on both sides of the module. Support the bottom of the module with one hand and hold the module with the other hand to insert the module into the slot along the rail.
- (5) Drive the levers close to the module, and the module will hit the back panel. The module will be fastened after self-locking of levers.

Figure 7-7 Replacing the Module (for RG-CS88-08)

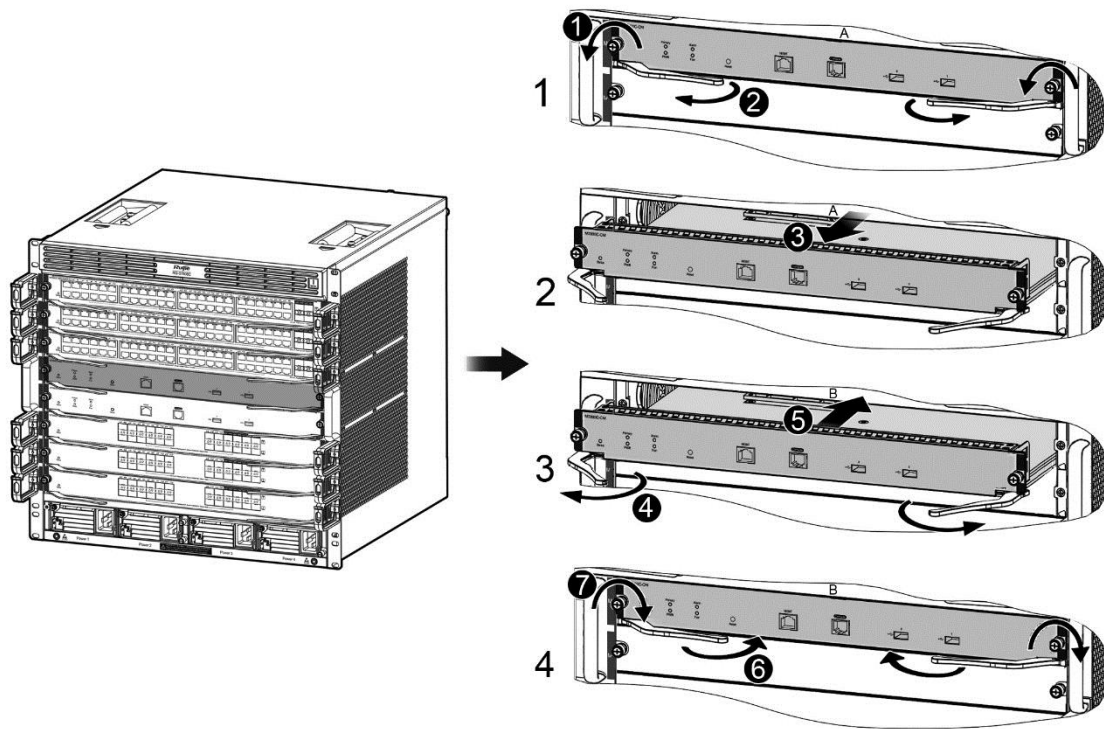

⚠ Caution

- In order to ensure the reliability of the system ventilation and heat dissipation performance and address the requirement of the dust-filter, filler panel needs to be installed in the slot where no supervisor module or service module has been installed.
- If you want to remove the module when the device is electrified, you need to insert the new module or install the filler panel within 10 minutes.
- Do not hold the edge of the PCB or collide the components on the PCB
- Do not plug/unplug a supervisor module or service module forcedly, use the ejector.

7.4 Removing Power Modules

Preparation

- (1) Wear an anti-static wrist strap close to your skin and have it properly grounded.
- (2) Take out the power module from the package.
- (3) Please power off the module before removing it.

⚠ Caution

- After hot swapping a module, please wait for at least 30 seconds for the next operation.
- Before inserting or removing the power module, please verify whether the switch is well mounted. Prevent the switch from tumbling down when you are inserting or removing the power module.
- Do not touch the connecting finger on the power module which has been removed to avoid being electrocuted in case of incomplete discharge.

Take the following steps to remove the power module on RG-CS88-08:

- (1) Unplug the cable. Separate the pigtail plug of the cable from the connector of the power module.
- (2) Unloosen the captive screws on the power module with the screwdriver.
- (3) Pull out the handle to make it vertical from the power panel.
- (4) Drag the power module panel with one hand and support the bottom of the power module with the other hand to pull out the power module.
- (5) Insert the power module into the slot until it hits the back panel.
- (6) Drive the handle close to the panel.
- (7) Tighten the captive screws on the panel with the screwdriver.

Figure 7-8 Removing the Power Module on RG-CS88-08

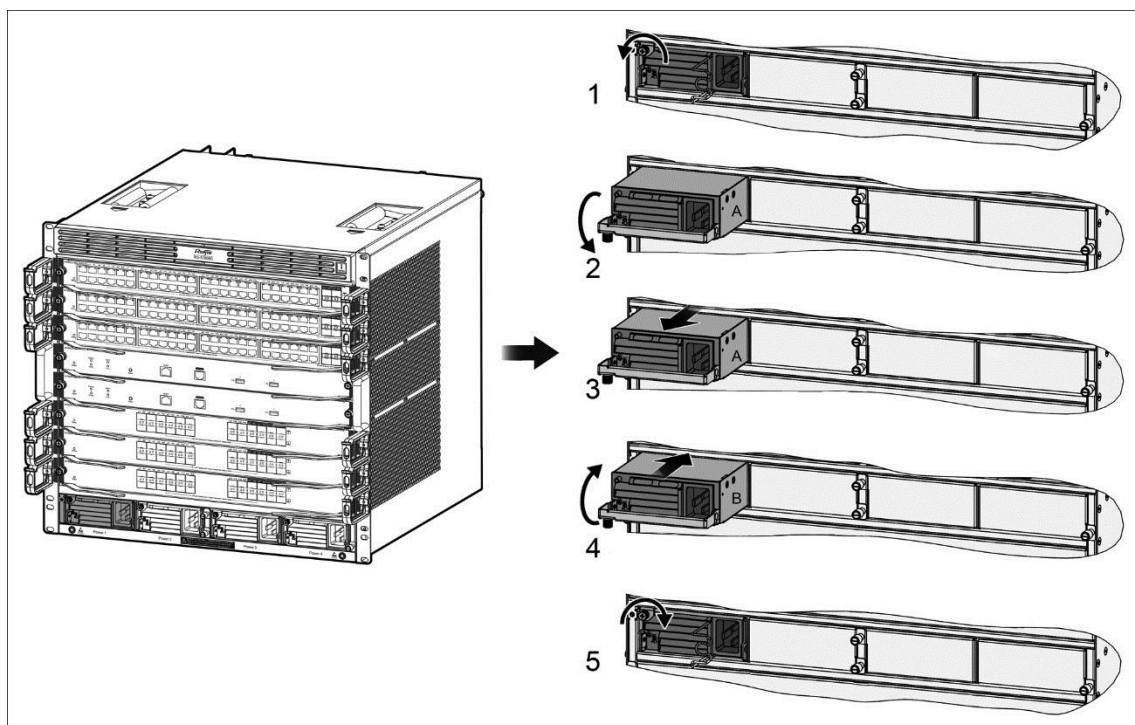

Note:	A: Power modules to be removed	B: Power module to be installed
-------	--------------------------------	---------------------------------

7.5 Removing Fans

Caution

- Do not touch any bare wire, terminal or the power instruction on the switch.
- The fan tray supports hot swapping, If you want to remove the fan tray when the switch is operational, do not remove the fan tray until the fan stops rotating, Besides, do not put your hands inside the fan tray.
- If you remove the fan tray when the switch is operational, install another fan tray quickly to ensure normal operation of the switch and avoid damage to the switch.

Preparation

- (1) Wear an anti-static wrist strap close to your skin and have it properly grounded.
- (2) Take out the fan module from the package.

Take the following steps to remove the fan module:

- (1) Unloosen the captive screws on the fan tray with the Phillips screwdriver.
- (2) Pull out the fan tray and put it in the anti-static bag.
- (3) Insert the fan tray into the slot along the slide rail until the fan tray hits the back panel.
- (4) Tighten the captive screws on the fan tray with the Phillips screwdriver.

Figure 7-9 Removing the Fan for RG-CS88-08

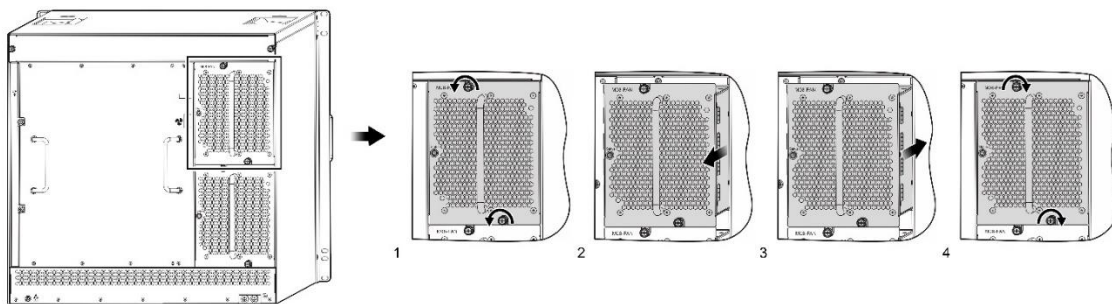

8 Cables

Note

This chapter describes the precautions and simple steps for cable connection and bundling. See *Appendix Cabling Recommendations* for detailed cabling and bundling.

8.1 Connecting the External Port Cables

Precautions

- Correctly distinguish single-mode and multi-mode fibers and ports.
- Avoid bends of small radius at the connector.

Simple Connection Steps

- (1) Connect one end of the RJ45 connector for configuring Ethernet cables to the Ethernet interface of the device module and the other end to the NMS or a control terminal; or connect one end of the standard RJ45 serial port cable to the serial port of the device module and the other end to the NMS or a control terminal.
- (2) Insert the single-mode or multi-mode fiber into the appropriate interface according to the identification on the panel of the module. Distinguish the Rx/Tx end of the fiber.
- (3) Insert the twisted pair with the RJ45 port into the appropriate interface according to the identification on the panel of the module. Distinguish the crossover cable and straight-through cable.
- (4) Connect the cables and fibers of each module in sequence.

8.2 Bundling the Cables

Precautions

- The power cables and other cables should be bundled in a visually pleasing way.
- When you bundle fibers, make sure that the fibers at the connectors have natural bends or bends of large radius.
- Do not bundle fibers and twisted pairs too tightly, as this may press hard the fibers and affect their useful life and transmission performance.

Simple Bundling Steps

- (1) Bundle the drooping part of the fibers and twisted pairs of each module, and lead them to both sides of the chassis for convenience.
- (2) On the both sides of the chassis, fasten the fibers and twisted pairs to the cabinet cable management ring or bracket.
- (3) For the power cables, you should bundle them closely along the bottom of the chassis, in a straight line wherever possible.

9 Appendix

9.1 Connectors and Media

1000BASE-T/100BASE-TX/10BASE-T

The 1000BASE-T/100BASE-TX/10BASE-T is a 10/100/1000 Mbps auto-negotiation port that supports auto MDI/MDIX.

Compliant with IEEE 802.3ab, 1000BASE-T requires Category 5e 100-ohm UTP or STP (STP is recommended) with a maximum distance of 100 meters (328 feet).

1000BASE-T requires all four pairs of wires be connected for data transmission, as shown in [Figure 9-1](#).

Figure 9-1 1000BASE-T Connection

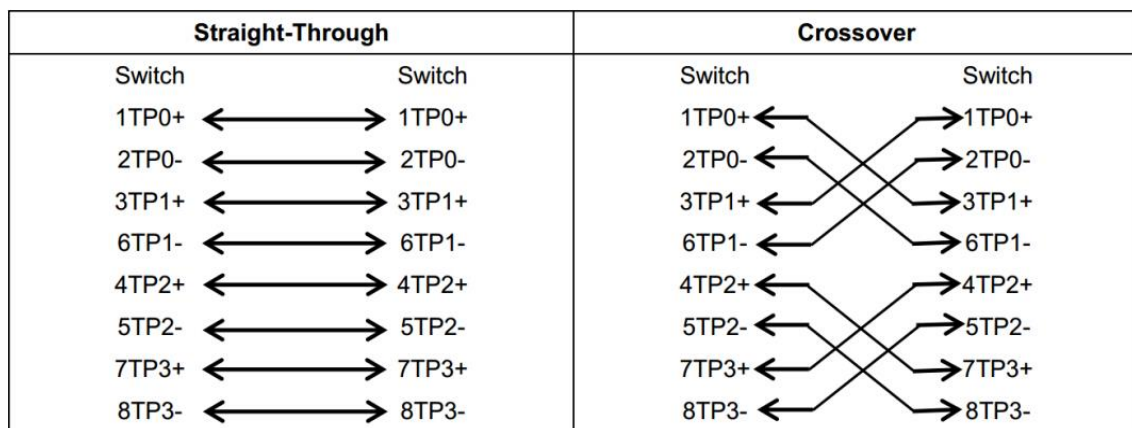

10BASE-T uses Category 3, 4, 5 100-ohm UTP/STP and 1000BASE-T uses Category 5 100-ohm UTP/STP for connections. Both support a maximum length of 100 meters. [Figure 9-2](#) shows 100BASE-TX/10BASE-T pin assignments.

Figure 9-2 100BASE-TX/10BASE-T Pin Assignments.

Pin	Socket	Plug
1	Input Receive Data+	Output Transmit Data+
2	Input Receive Data-	Output Transmit Data-
3	Output Transmit Data+	Input Receive Data+
6	Output Transmit Data-	Input Receive Data-
4,5,7,8	Not used	Not used

[Figure 9-3](#) shows wiring of straight-through and crossover cables for 100BASE-TX/10BASE-T.

Figure 9-3 100BASE-TX/10BASE-T Connection

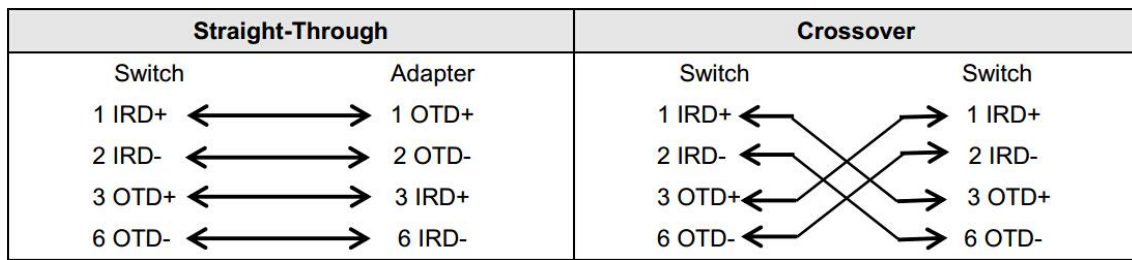

Fiber Connection

You can choose to use single mode or multimode fibers according to the transceiver module types. [Figure 9-4](#) shows connection of fiber cables.

Figure 9-4 Fiber Connection

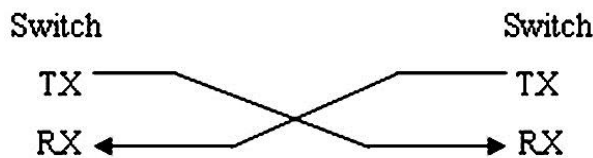

9.2 Switch Lightning Protection

Installing AC Power Arrester (lightning protection cable row)

The external lightning protection cable row shall be used on the AC power port to prevent the switch from being struck by lightning when the AC power cable is introduced from the outdoor and directly connected to the power port of the switch. The lightning protection cable row is fixed on the cabinet, operating table or the wall in the machine room using the line buttons and screws.

Figure 9-5 Schematic Diagram for the Power Arrester

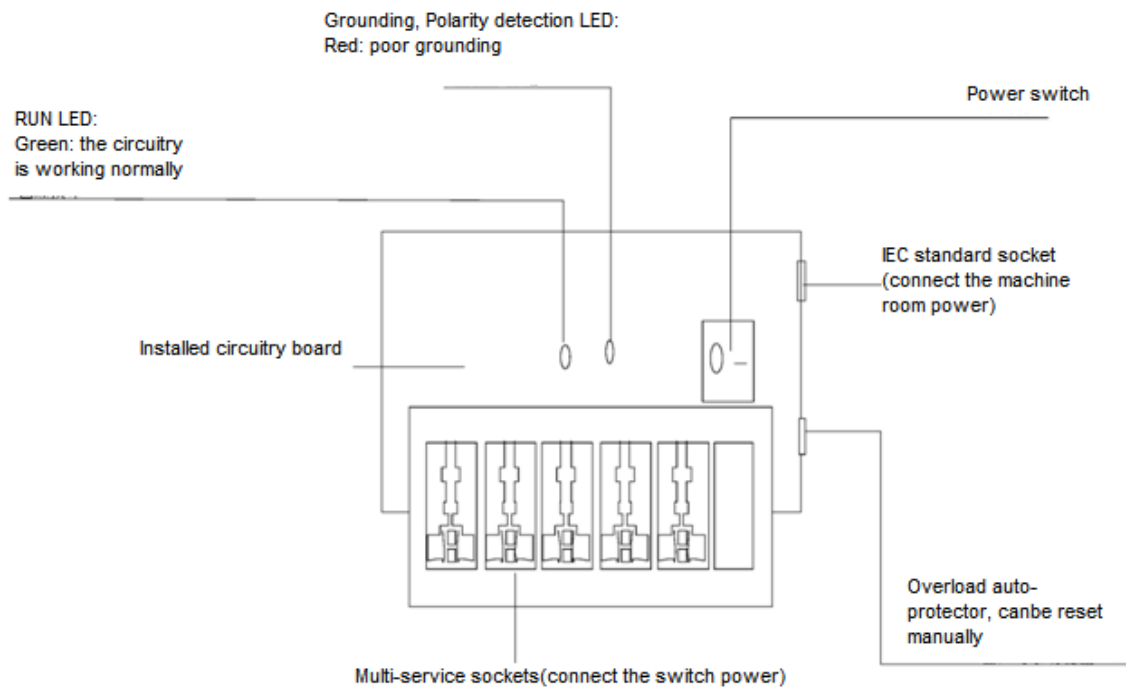

Note

The power arrester is not provided and the user shall purchase it to address the practical requirement.

Caution

- Make sure that the PE terminal of the power arrester has been well-grounded;
- After connecting the switch AC power plug to the socket of the power arrester (lightning protection socket), lightning protection function implements if the RUN LED is Green and the ALARM LED is OFF.
- If the ALARM LED on the power arrester is Red, you shall check what the reason is, poor grounding connection or the reversed connection of the Null and Live lines: Use the multimeter to check the polarity of the power socket for the arrester when the LED is Red, if the N line is on the left and the L line is on the right, the arrester PE terminal is not grounded; if the L line is on the left and the N line is on the right, the polarity of the arrester power cable shall be reversed; if the LED is still Red, it is confirmed that the arrester PE terminal has not been grounded.

Installing the Ethernet Port Arrester

During the switch usage, the Ethernet port arrester shall be connected to the switch to prevent the switch damage by lightning before the outdoor network cable connects to the switch.

Tools: Cross or straight screwdriver, Multimeter, Diagonal pliers

Installation Steps:

- (1) Tear one side of the protection paper for the double-sided adhesive tape and paste the tape to the framework of the Ethernet port arrester. Tear the other side of the protection paper for the double-sided adhesive tape and paste the Ethernet port arrester to the switch framework. The paste location for the Ethernet port arrester shall be as close to the grounding terminal of the switch.

- (2) Based on the distance of the switch grounding terminal, cut the grounding line for the Ethernet port arrester and firmly tighten the grounding line to the grounding terminal of the switch.
- (3) Use the multimeter to check whether the grounding line for the arrester is in good contact with the switch grounding terminal and the framework.
- (4) According to the description on the Ethernet Port Arrester Hardware Installation Guide, connect the arrester using the adapter cable (note that the external network cable is connected to the end of IN, while the adapter cable connected to the switch is connected to the end of OUT) and observe whether the LED on the board is normal or not.
- (5) Use the nylon button to bundle the power cables.

Figure 9-6 Schematic Diagram for the Ethernet port Arrester Installation

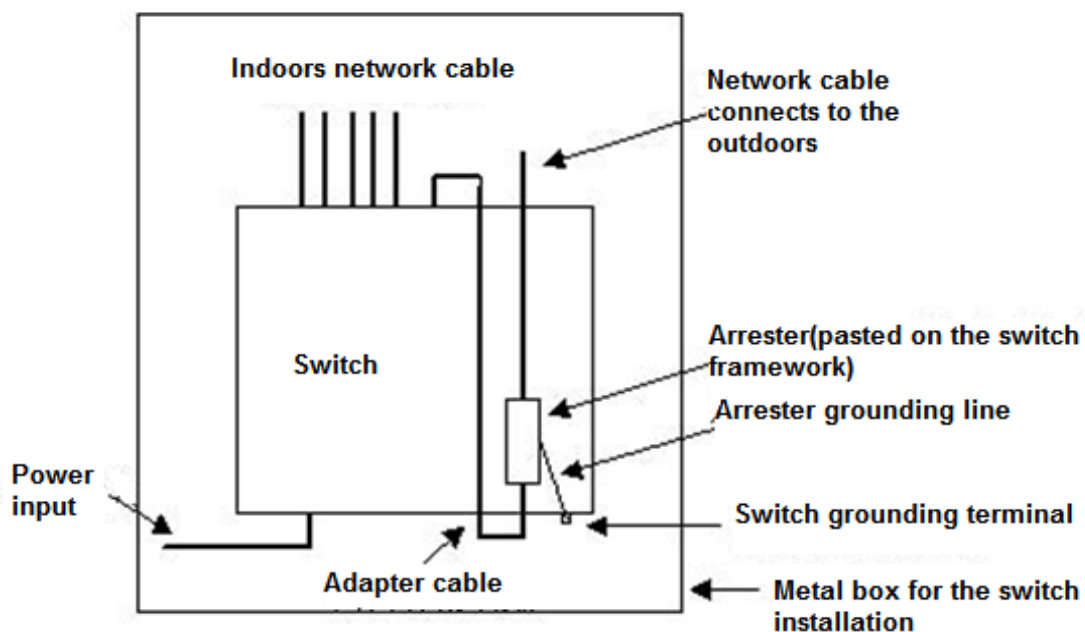

⚠ Caution

- The Ethernet port arrester is only for the 10M/100M copper Ethernet ports with the RJ-45 connector;
- The Ethernet port arrester is not provided, the user can purchase them to address their own practical requirements. For the detailed information during the arrester installation, please refer to Ethernet Port Arrester Hardware Installation Guide, which contains the technical specification and the maintenance and installation of the arrester.

You may pay attention to the following conditions during the actual installation to avoid influencing the performance of the Ethernet port arrester:

- Reversed direction of the arrester installation. You shall connect the external network cable to the “IN” end and connect the switch Ethernet port to the “OUT” end.
- Poor arrester grounding. The length of the grounding line should be as short as possible to ensure that it is in good contact with the switch grounding terminal. Use the multimeter to confirm the contact condition after the grounding.

Incomplete arrester installation. If there is more than one port connected to the peer device on the switch, it needs to install the arresters on all connection ports for the purpose of the lightning protection.

9.3 Cabling Recommendations

When RG-CS88-08 series switches are installed in standard 19-inch cabinets, route cable bundles upward or downward along the sides of the rack depending on the actual situation in the equipment room. All cable connectors should be placed at the bottom of the cabinet rather than be exposed outside of the cabinet. Power cords should be routed upward or downward beside the cabinet close to the location of the DC power distribution cabinet, AC power outlet, or lightning protection box.

Required Minimum Cable Bend Radius

- The minimum bend radius of a power, communication or flat cable should be 5 times the overall diameter of the cable. If the cable is constantly bent, plugged or unplugged, the bend radius should be 7 times the overall diameter.
- The minimum bend radius of a coaxial cable should be 7 times the overall diameter of the cable. If the cable is constantly bent, plugged or unplugged, the bend radius should be 10 times the overall diameter.
- The minimum bend radius of a high-speed cable, such as an SFP+ cable should be 5 times the overall diameter of the cable. If the cable is constantly bent, plugged or unplugged, the bend radius should be 10 times the overall diameter. Required minimum fiber bend radius
- The diameter of a fiber tray to hold fibers cannot be less than 25 times the diameter of the fiber.
- When moving an optical fiber, the bend radius of the fiber should be equal to or greater than 20 times the diameter of the fiber.
- During cabling of an optical fiber, the bend radius of the fiber should be equal to or greater than 10 times the diameter of the fiber.

Precautions for Cable Bundling

- Before bundling cables, correctly mark labels and stick the labels to cables where appropriate.
- Cables should be neatly and properly bundled, as shown in [Figure 9-7](#).

Figure 9-7 Bundling Cables

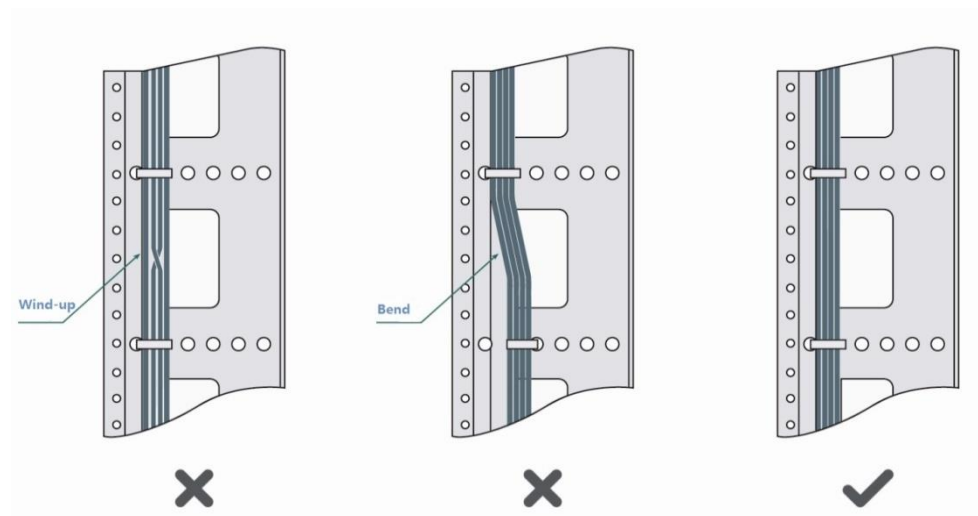

- Route and bundle power, signal, ground cables separately. When the cables are close to each other, cross them. When power cables run parallel to signal cables, the distance between them must be
- All cable trays and their accessories shall be smooth and free from sharp edges.
- Holes in metal, through which cables pass shall have smooth, well-rounded surfaces or be protected with insulating bushings.
- Use proper cable ties to bind cables together. Do not tie two or more cable ties to bind cables.
- Cut off excess cable tie cleanly with no sharp edges after bundling cables, as shown in [Figure 9-8](#).

Figure 9-8 Cutting off Excess Cable Tie

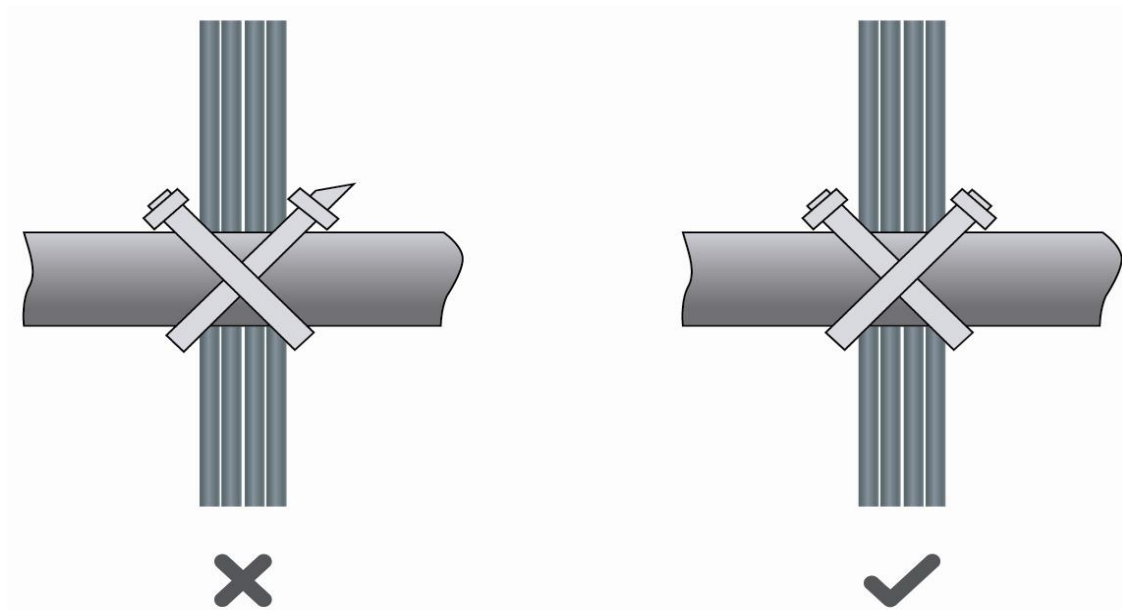

- If cables are to be bent, bind them first but do not tie cable ties within the bend to avoid stress on the cables, which may otherwise cause the wires inside to break, as shown in [Figure 9-9](#).

Figure 9-9 Do Not Tie Cable Ties within the Bend

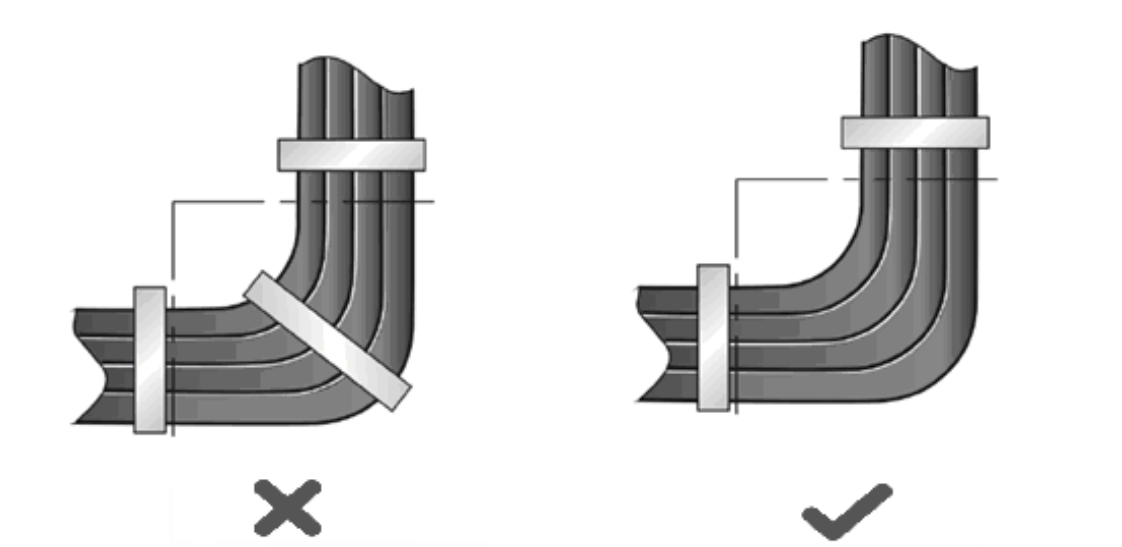

- Wrap up unnecessary or excess cables and bind them to the appropriate rack position, where device operation is not affected and no damages occur to the device and cables during debugging.
- Do not bind power cords to the rails for moving parts.
- Leave a certain length of the cable connecting moving parts, such as the ground wire of the cabinet door, to avoid stress on the cable; When moving parts are in place, ensure the excess cable length shall not contact heat sources, sharp corners or edges. If heat sources are unavoidable, use high-temperature cables instead.
- When using screws to fasten cable lugs, the bolts or nuts shall be tightened and prevented from loosening, as shown in [Figure 9-10](#).

Figure 9-10 Fastening Cable Lugs

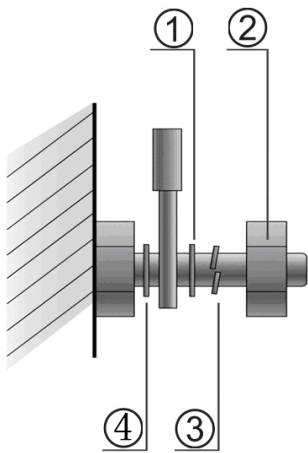

Note	(1) Flat washer	(3) Spring washer
	(2) Nut	(4) Flat washer

- When using a stiff cable, fix it near the cable lug to avoid stress on the lug and cable.
- Do not use self-tapping screws to fasten terminals.
- Bundle cables of the same type and running in the same direction into groups. Keep cables clean and straight.
- Cables shall be tied according to the following table.

Diameter of Cable Bundle (mm)	Space between Bundles (mm)
10	80 to 150
10 to 30	150 to 200
30	200 to 300

- Do not tie knots for cables or cable bundles.
- The metal parts of the cold-pressed terminal blocks, such as air circuit breakers, shall not be exposed outside of the blocks.

9.4 Site Selection

- The machine room should be at least 5km away from the heavy pollution source such as the smelter, coal mine and thermal power plant, 3.7km away from the medium pollution source such as the chemical industry, rubber industry and electroplating industry, and 2km away from the light pollution source such as the food manufacturer and leather plant. If the pollution source is unavoidable, the machine room should be located on the windward side of the pollution source perennially with advanced protection.
- The machine room should be at least 3.7km away from the sea or salt lake. Otherwise, the machine room must be sealed, with air conditioner installed for temperature control. Saline soil cannot be used for construction. Otherwise, you should select devices with advanced protection against severe environment.
- Do not build the machine room in the proximity of livestock farms. Otherwise, the machine room should be located on the windward side of the pollution source perennially. The previous livestock house or fertilizer warehouse cannot be used as the machine room.
- The machine room should be firm enough to withstand severe weather conditions such as windstorm and heavy rain as well as away from dust. If the dust is unavoidable, keep the door and window away from the pollution source.
- The machine room should be away from the residential area. Otherwise, the machine room should meet the construction standard in terms of noise.
- Make sure the air vent of the machine room is away from the sewage pipe, septic tank, and sewage treatment tank. Keep the machine room under positive pressure to prevent corrosive gas from entering the machine room to corrode components and circuit boards. Keep the machine room away from industrial boiler and heating boiler.
- The machine room had better be on the second floor or above. Otherwise, the machine room floor should be 600mm higher than the highest flood level ever recorded.
- Make sure there are no cracks or holes in the wall and floor. If there are cable entries in the wall or window, take proper sealing measures. Ensure that the wall is flat, wear-resistant, and dust-free, which should be up to the standard for flame retarding, soundproofing, heat absorption, dust reduction, and electromagnetic shielding.
- Keep the door and the window closed to make the machine room sealed.
- The steel door is recommended for soundproofing.
- Sulfur-containing materials are forbidden.
- Pay attention to the location of the air conditioner. Keep the air conditioner from blowing wind straight toward the device or blowing water drops from the window or air vent toward the device.